

Tracking the baryon quantum number with heavy-ion collisions

Chun Yuen Tsang, for the STAR Collaboration

Kent State University and Brookhaven National Laboratory

APS Topical Group on Hadronic Physics

Supported in part by:



U.S. DEPARTMENT OF
ENERGY

What carries baryon number, quark vs. baryon junction?

Conventional picture

<https://en.wikipedia.org/wiki/Quark>

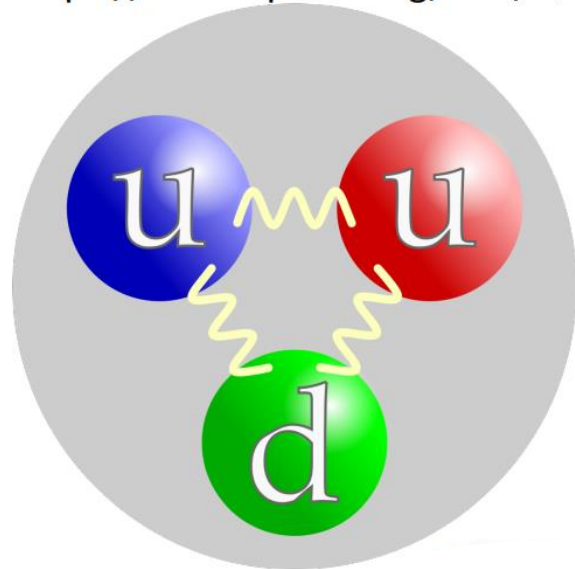

Baryon junction [1, 2]

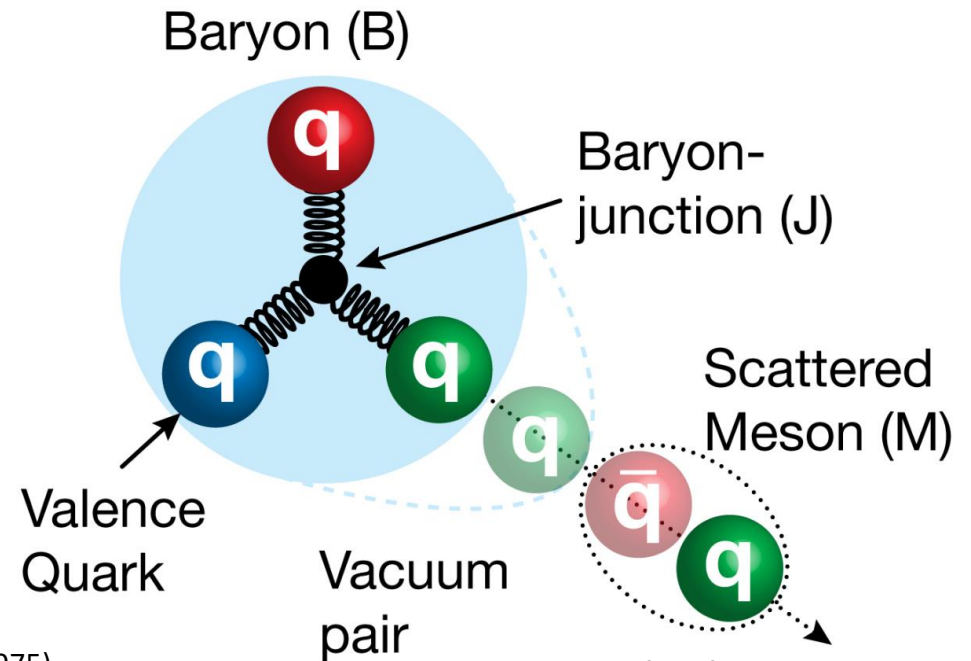

[1]: Artru, X. String Model with Baryons: Topology, Classical Motion. Nucl. Phys. B 85, 442–460 (1975).

[2]: Rossi, G. C. & Veneziano, G. A Possible Description of Baryon Dynamics in Dual and Gauge Theories. Nucl. Phys. B 123, 507–545 (1977)

P. Tribedy, WPCF 2022

Baryon stopping

- **Net baryon (number of baryons – anti-baryons) in mid-rapidity region has been observed to be enhanced.**
- **Quarks carry most momentum, are contracted into thin “pancakes”.**
 - Quarks have less time to interact due to contracted longitudinal length.
- **Junction carries lower momentum, is less contracted.**
 - Junctions have more time to interact with other partons.
 - More baryons are expected to be stopped in junction picture.
- **Two methods to test the hypothesis:**
 - Photonuclear collisions.
 - baryon stopping vs. charge stopping.

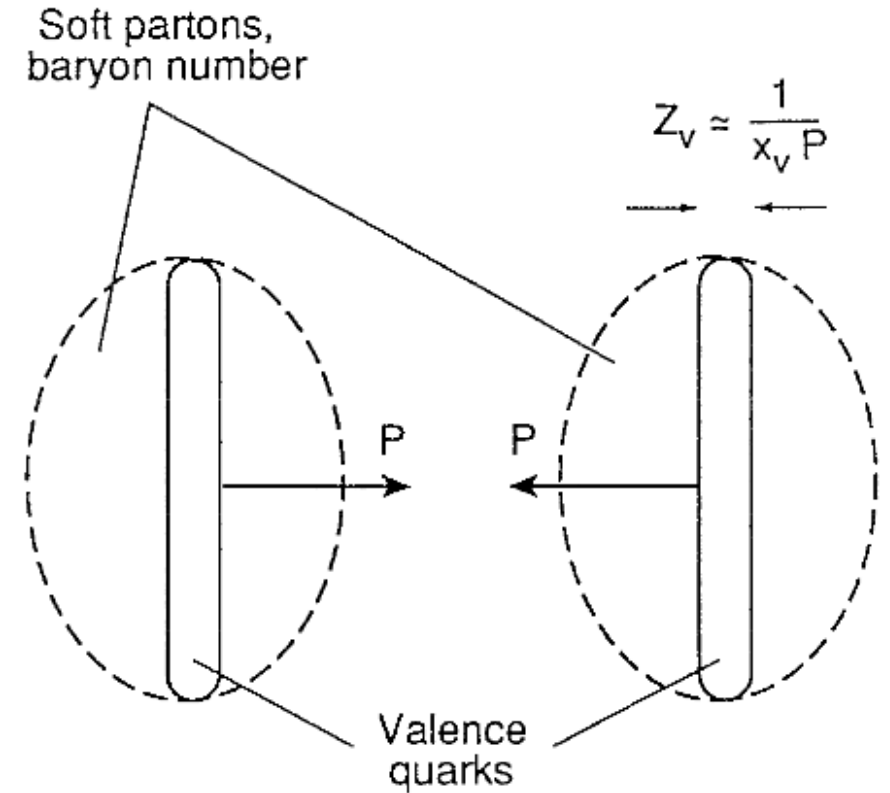

Fig. 2.

Figure from D. Kharzeev, Physics Letters B 378, 238 (1996)

1st Method: photonuclear collisions

If junction hypothesis is true:

- Virtual photon fluctuates into q and \bar{q} pair.
- Interact with a junction in target Au nucleus.
- May result in exchange of junction.
 - Depicted as exchange of junctions by the dashed line.
 - Flavor-blind process, so red and blue dots can represent different baryons.
- Enhanced creation of mid-rapidity baryons.
 - Junction interaction time $>$ quark interaction time.
 - More baryons are stopped in junction picture.
- Predicted rapidity distribution of $dN/dy \propto e^{-a(y-y_{beam})}$ in the direction of the target. a is related to Regge intercept of junctions (J. D. Brandenburg, N. Lewis, P. Tribedy, Z. Xu, arXiv:2205.05685 (2022)).

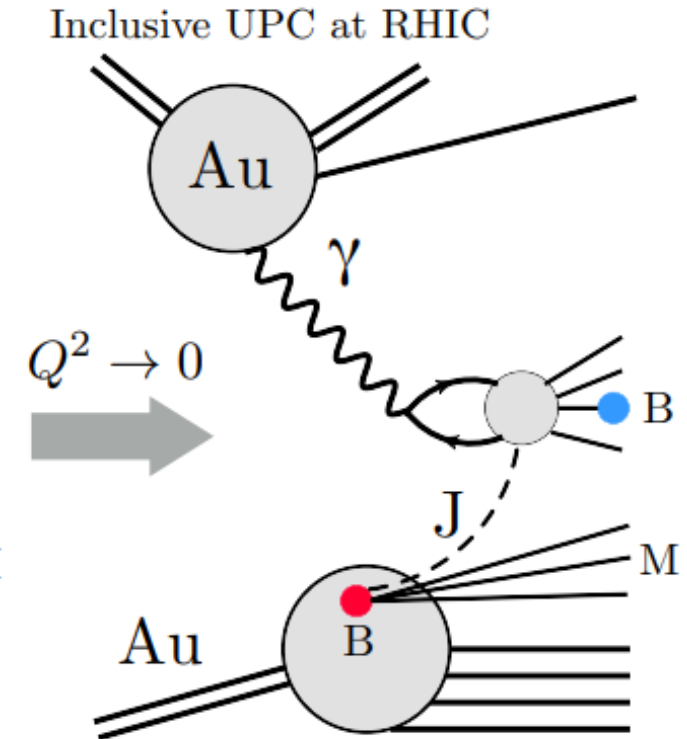
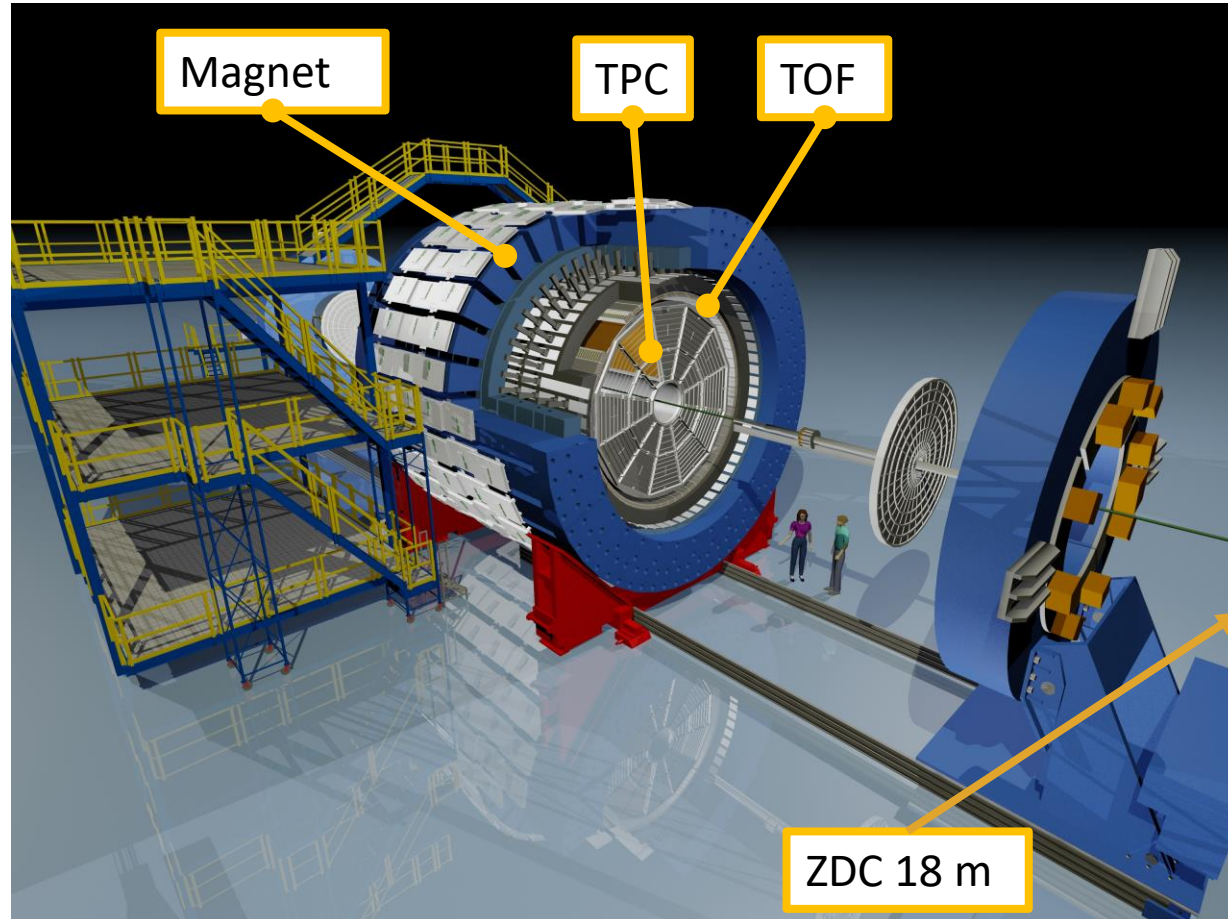

Figure from J. D. Brandenburg, N. Lewis, P. Tribedy, Z. Xu, arXiv:2205.05685 (2022)



STAR detector



- **Time Projection Chamber (TPC)**
 - Measures charged particle momentum with track curvature under B-field.
 - Particle identification with energy loss per unit length (dE/dx).
- **Time-Of-Flight (TOF)**
 - Extends momentum range for particle identification.
 - Pile-up rejection.
- **Zero Degree Calorimeter (ZDC)**
 - Detect forward neutrons for event selection.

Selecting photonuclear events in Au + Au collisions at $\sqrt{s_{NN}} = 54.4$ GeV

- Select events with single neutron (1n) on ZDC east (ZDCE), no activity in BBC east, and multiple neutron (Xn) on ZDC west (ZDCW) and activity in BBC west and vice versa.

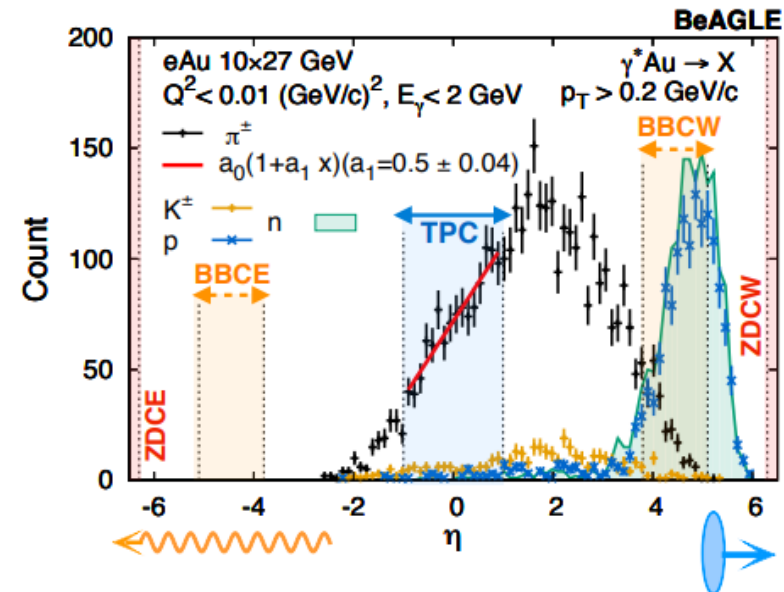
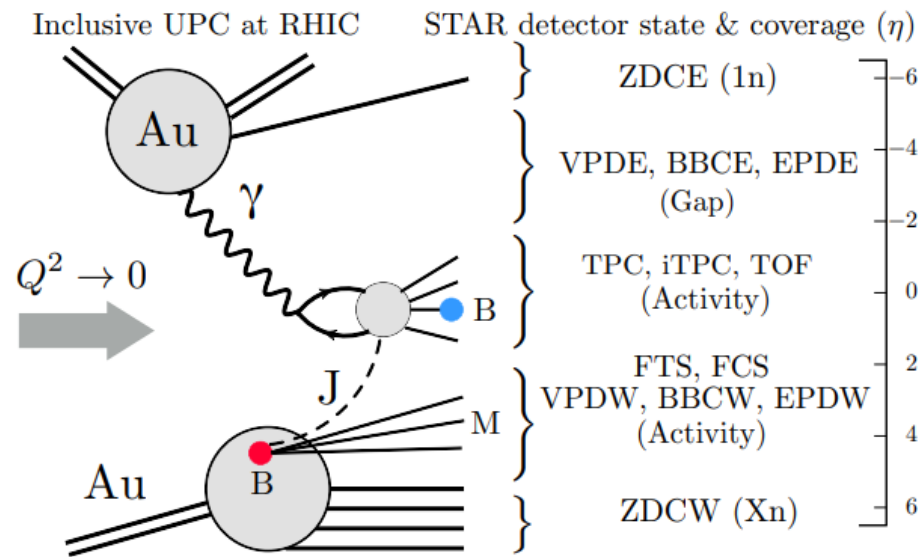

Figures from J. D. Brandenburg, N. Lewis, P. Tribedy, Z. Xu, arXiv:2205.05685 (2022)



Net-proton yield as a proxy for net-baryon

- Net-proton yield is described by $\exp(- (1.13 \pm 0.32)(y - y_{beam}))$
- PYTHIA-6, which has valence quark as baryon number carrier, predicts a dependence of $\exp(-2.5(y - y_{beam}))$ [1, 2, 3]
- Comparable to slopes from Au + Au collisions.
 - Consistent with Regge theory prediction for baryon junction

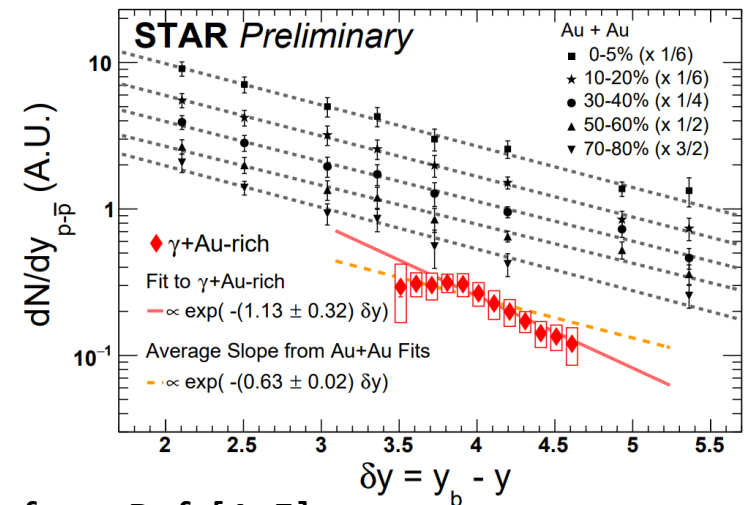
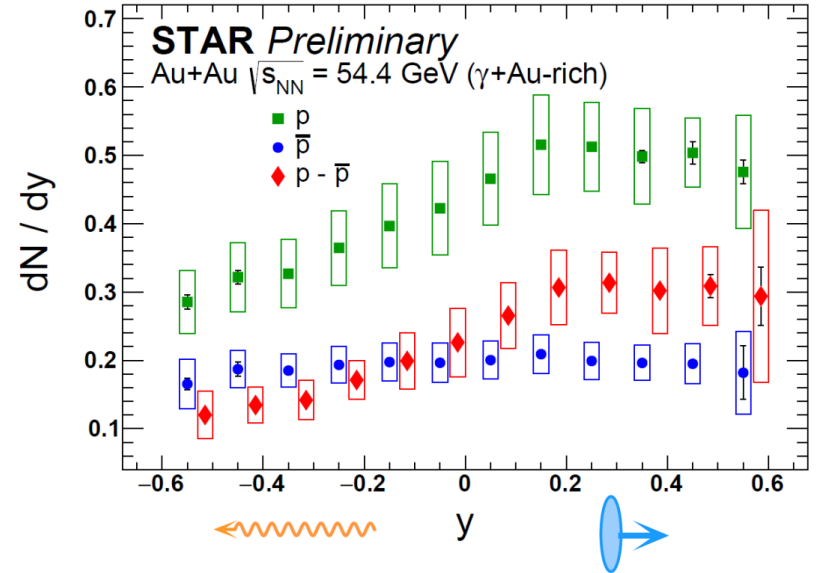

[1]: J. D. Brandenburg, N. Lewis, P. Tribedy, Z. Xu, arXiv:2205.05685 (2022)
 [2]: B. Andersson, G. Gustafson, G. Ingelman, and T. Sjöstrand, Physics Reports 97, 31–145 (1983).
 [3]: Torbjorn Sjostrand, Stephen Mrenna, and Peter Z. Skands, JHEP 05, 026 (2006), arXiv:hep-ph/0603175.
 [4]: STAR Collaboration, PRC 79, 034909 (2009)
 [5]: STAR Collaboration, PRC 96, 044904 (2017)



2nd Method : baryon stopping vs. charge stopping

- Quarks carry charge number. If the baryon number is not carried by valence quarks, “distribution” of baryon and charge numbers could be different (J. D. Brandenburg, N. Lewis, P. Tribedy, Z. Xu, arXiv:2205.05685 (2022)).
- Define net-baryon number $B = (N_p - N_{\bar{p}}) + (N_n - N_{\bar{n}})$
- Define net-charge number $Q = (N_{\pi^+} + N_K^+ + N_p) - (N_{\pi^-} + N_K^- + N_{\bar{p}})$
- Question: $\Delta Q = Q(Ru + Ru) - Q(Zr + Zr) = ??? \frac{B\Delta Z}{A}$ (at $|y| < 0.5$)



If baryon number and charge number are carried by the same object.

Very simplified argument:

- No. of baryons in participant region = $96 \cdot \text{Const}$.
 - ${}^{96}_{44}\text{Ru}, {}^{96}_{40}\text{Zr}$
- No. of protons in participant region for Ru+Ru = $96 \cdot \text{Const} \cdot 44/96$
- No. of protons in participant region for Zr+Zr = $96 \cdot \text{Const} \cdot 40/96$
- So $B_{init} = 96 \cdot \text{Const}$, $\Delta Q_{init} = Q_{init} (\text{Ru} - \text{Zr}) = 96 \cdot \text{Const} \cdot 4/96$
- If baryon number and charge number are carried by the same object (presumably quarks), $B/\Delta Q \cdot \Delta Z/A$ should be 1 throughout the collision evolution at mid-rapidity.

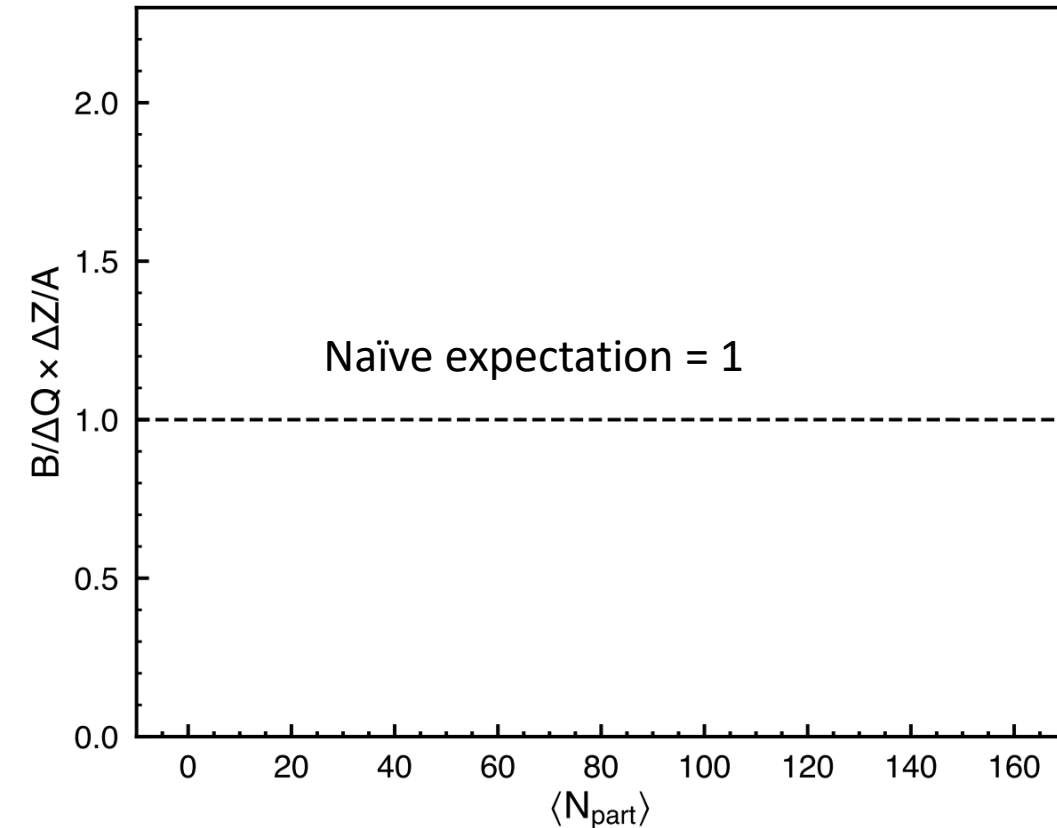



If baryon junction hypothesis is true.

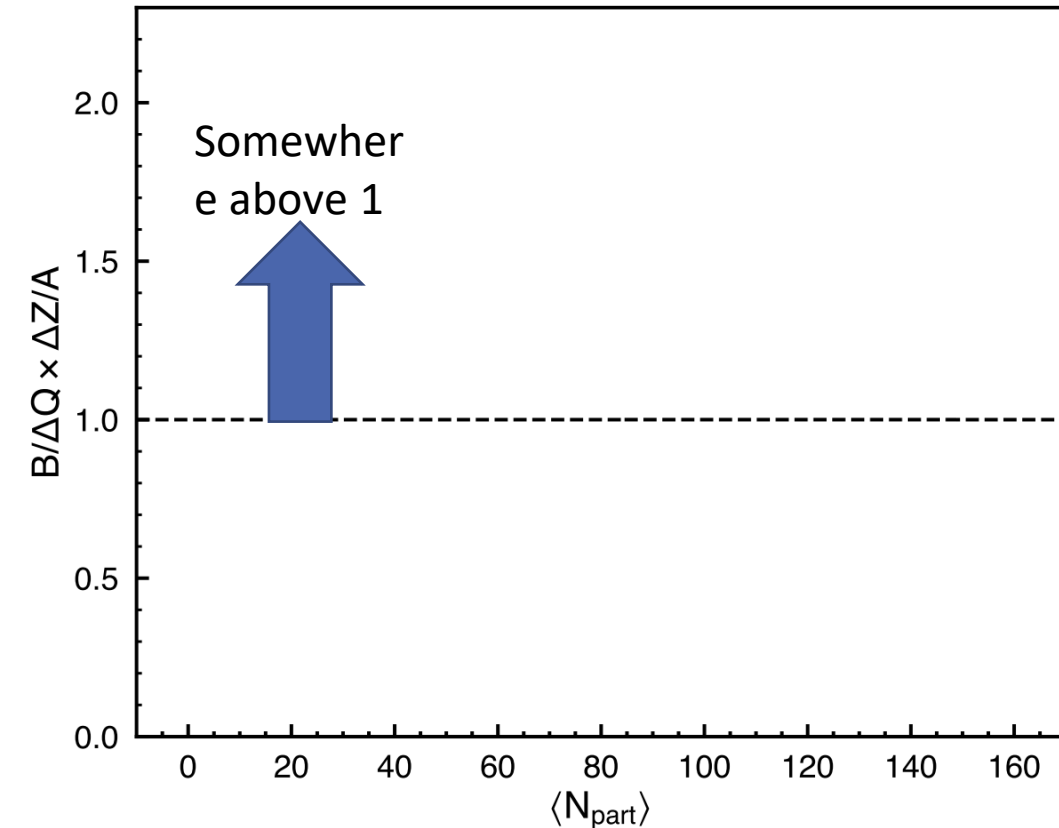

- Baryon junction only carries a fraction of valence quark's momentum.
- Junction has enough time to interact => More baryon stopping.
- Baryon stopping > charge stopping.

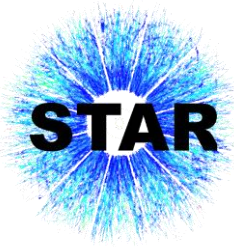

Net-baryon number B_{net}

- $B_{net} = (N_p - N_{\bar{p}}) + (N_n - N_{\bar{n}})$
- **We don't measure (anti-)neutron spectrum. Approximated by thermal model assumption**
- $B_{net} = (N_p - N_{\bar{p}}) + \bar{p} \sqrt{\frac{d}{\bar{d}}} - p \sqrt{\frac{\bar{d}}{d}}$

Assumption

In the framework of statistical thermal models [58] the particle multiplicity from a source of volume V and chemical freeze-out temperature T is given by

$$N_i = \frac{g_i V}{\pi^2} m_i^2 T K_2(m/T) \exp(\mu_i/T), \quad (7)$$

where g_i , m_i , and μ_i are the degeneracy, particle mass, and chemical potential of particle species i , respectively. This formula is valid in the Boltzmann approximation, which is reasonable for all hadrons and light nuclei. The chemical potential can be expressed as $\mu_i = B_i \mu_B + S_i \mu_S + Q_i \mu_Q$, where B_i , S_i , and Q_i are the baryon number, strangeness, and charge, respectively, of particle species i , and μ_B , μ_S , and μ_Q are the corresponding chemical potentials for these conserved quantum numbers.

$$\begin{aligned} N_d &= F(m_d, T) \exp(2\mu_B + \mu_Q) \\ N_{\bar{d}} &= F(m_d, T) \exp(-2\mu_B - \mu_Q) \\ N_p &= F(m_p, T) \exp(\mu_B + \mu_Q) \\ N_{\bar{p}} &= F(m_p, T) \exp(-\mu_B - \mu_Q) \\ N_n &= F(m_n \approx m_p, T) \exp(\mu_B) \end{aligned}$$

Therefore,

$$\begin{aligned} \frac{d}{p^2} &= \frac{F(m_d, T)}{F(m_p, T)^2} \exp(-\mu_Q) \\ \frac{\bar{d}}{\bar{p}^2} &= \frac{F(m_d, T)}{F(m_p, T)^2} \exp(\mu_Q) \\ \frac{n}{p} &= \exp(-\mu_Q) \end{aligned}$$

Therefore,

$$\frac{n}{p} = \sqrt{\frac{d/p^2}{\bar{d}/\bar{p}^2}} = \frac{\bar{p}}{p} \sqrt{\frac{d}{\bar{d}}}$$

Extracted from STAR Collaboration, PRC 99, 064905 (2019)



Net-charge difference ($R_u + R_u - Z_r + Z_r$)

- $R2_\pi = \frac{(N_\pi^+/N_\pi^-)_{Ru}}{(N_\pi^+/N_\pi^-)_{Zr}} \approx \frac{[1+(N_\pi^+-N_\pi^-)/N_\pi]_{Ru}}{[1+(N_\pi^+-N_\pi^-)/N_\pi]_{Zr}} = \frac{1+\Delta R_{Ru}}{1+\Delta R_{Zr}} \approx 1 + \Delta R_{Ru} - \Delta R_{Zr}$
- $\Delta Q = [(N_\pi^+ + N_K^+ + N_p) - (N_\pi^- + N_K^- + N_{\bar{p}})]_{Ru} - []_{Zr}$
- Focus on pion terms,
- $(N_\pi^+ - N_\pi^-)_{Ru} - (N_\pi^+ - N_\pi^-)_{Zr} = N_{\pi,Ru} \times \Delta R_{Ru} - N_{\pi,Zr} \times \Delta R_{Zr}$
- $\approx N_\pi (\Delta R_{Ru} - \Delta R_{Zr}) = N_\pi \times (R2_\pi - 1)$
- Where $N_\pi = 0.5 \times (N_\pi^+ + N_\pi^-)$
- Therefore, $\Delta Q = N_\pi (R2_\pi - 1) + N_K (R2_K - 1) + N_p (R2_p - 1)$



Recap what are needed.

- **For baryon stopping B ,**
 - $N_p, N_{\bar{p}}, N_d, N_{\bar{d}}$ for Ru+Ru and Zr+Zr
- **For charge stopping difference ΔQ ,**
 - $N_{\pi}^+, N_K^+, N_p, N_{\pi}^-, N_K^-, N_{\bar{p}}$ for Ru+Ru and Zr+Zr
 - $R2_{\pi}, R2_K, R2_p$

Spectra from Isobar

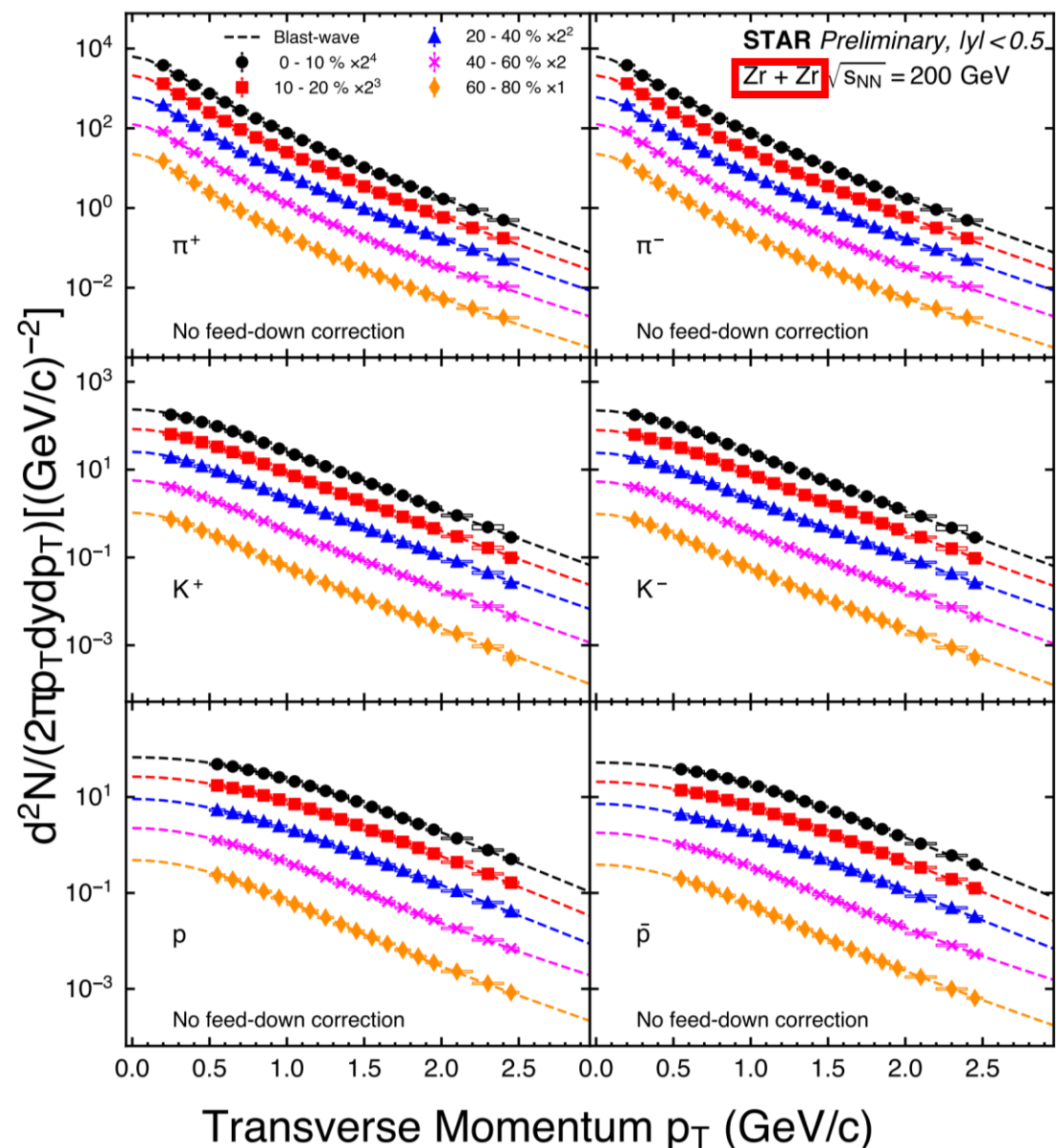
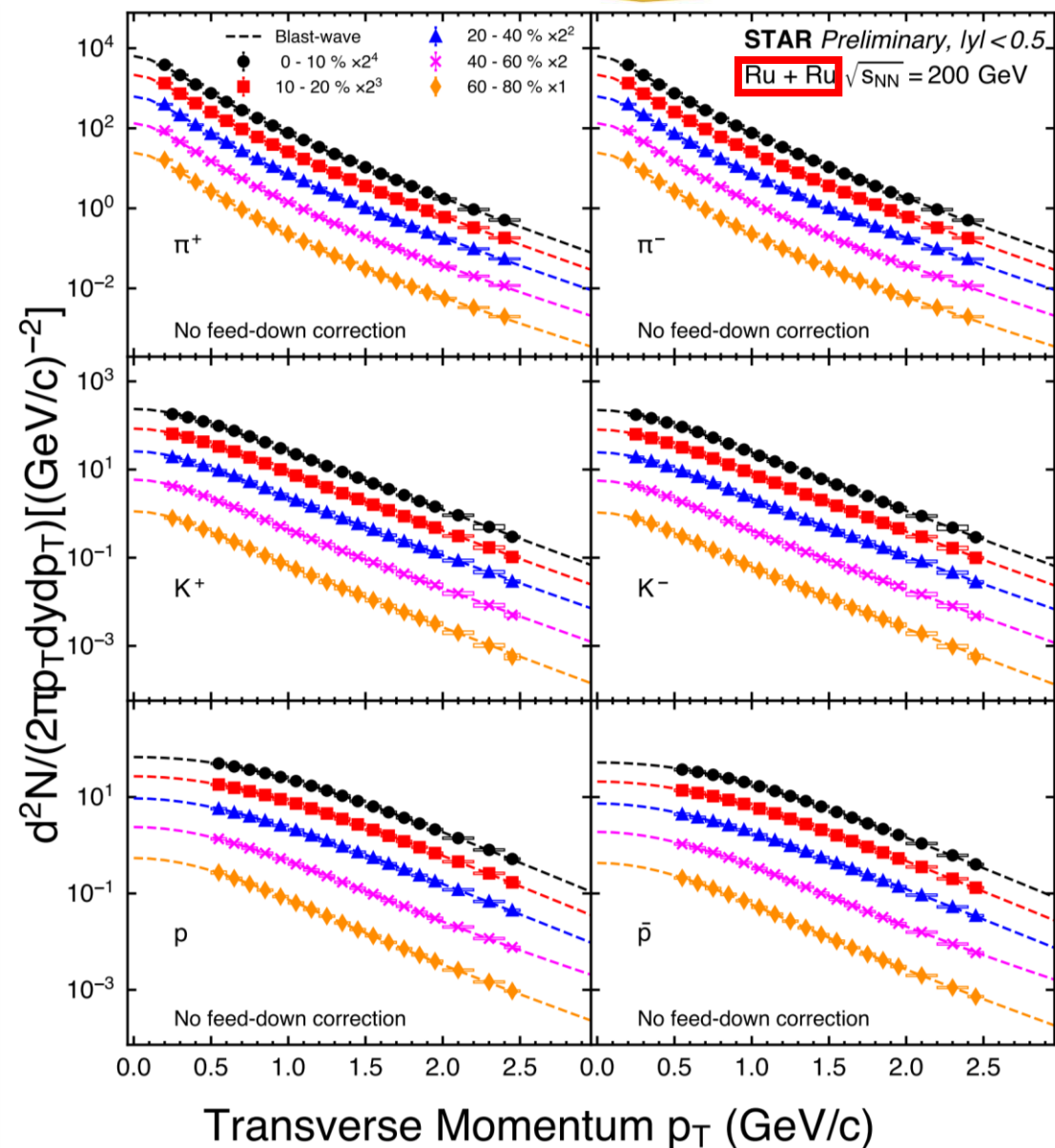

Double ratio R2s

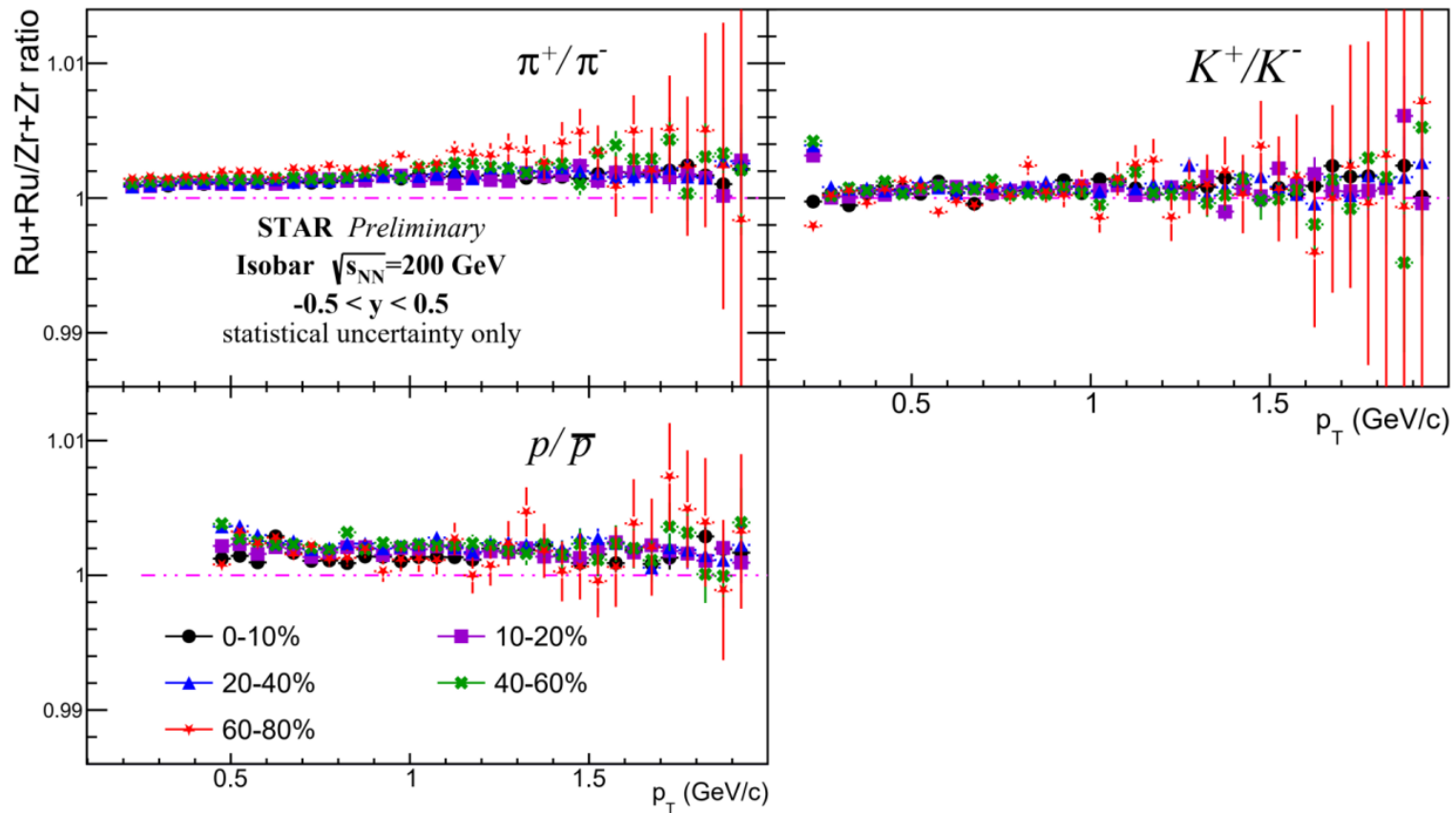



Charge and baryon stopping compared to UrQMD separately

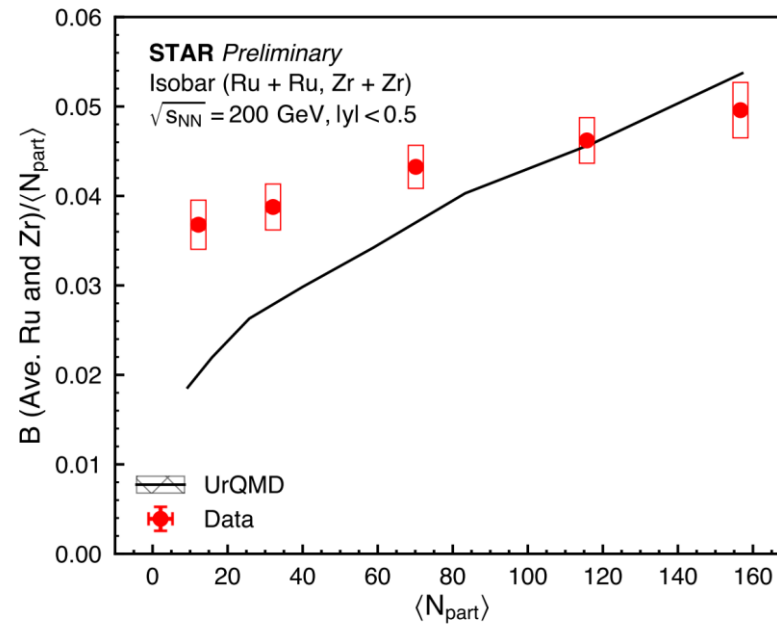
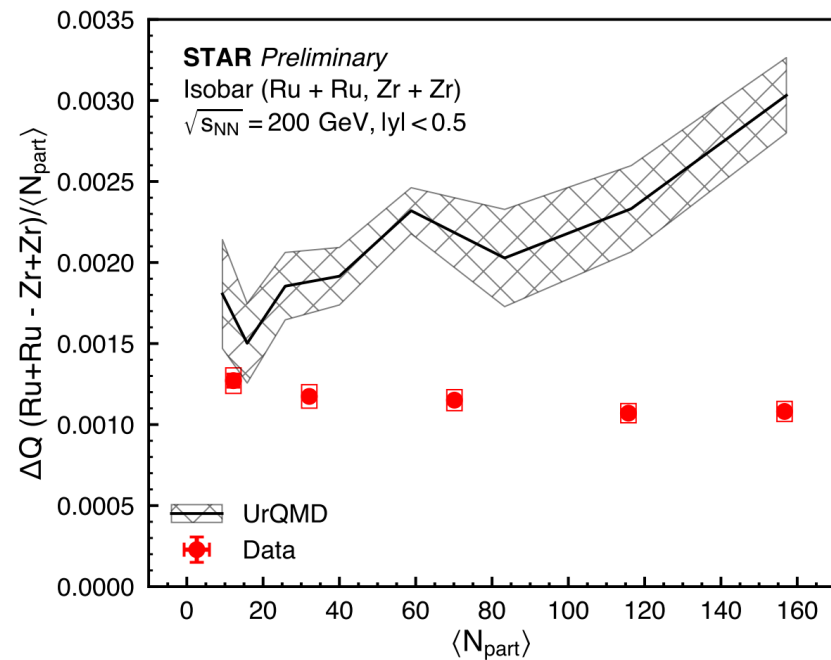

- **UrQMD accurately reproduces baryon stopping at mid-rapidity in central collisions but not ΔQ , probably because UrQMD has been tuned to net-proton measurements.**
- **Accurate measurement of charge stopping can be used for model tuning.**

Experimental result on baryon stopping and charge stopping

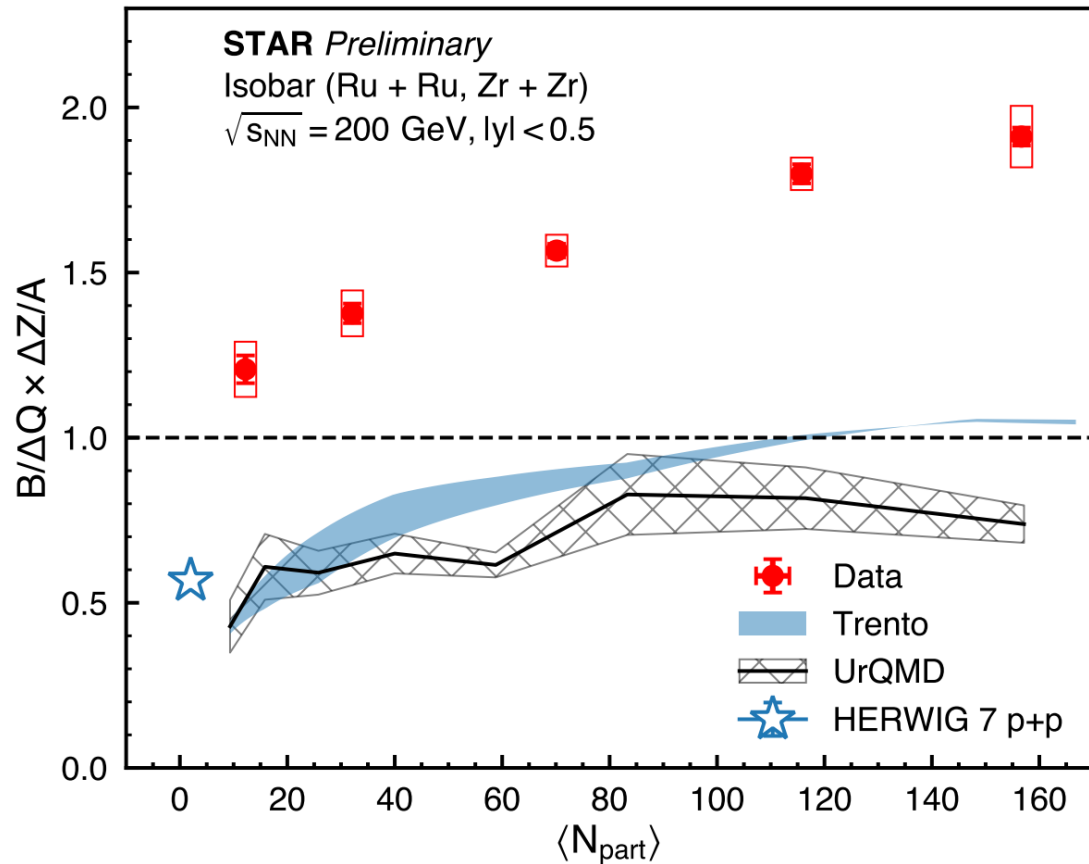

- $B/\Delta Q * \Delta Z/A > 1$. It deviates from the naive expectation of valence quark as baryon number carrier.
- Model calculations assuming valence quark carries baryon number (Herwig $p + p$ ($B/Q * Z/A, Z=A=1$) [1] and UrQMD [2]) cannot describe our data
- Decrease with decreasing $\langle N_{part} \rangle$, consistent with nuclear skin thickness difference between Ru and Zr.
 - Trento model [3] accounts for initial conditions only, so the drop only represents nucleus geometry.

[1]: J. Bellm et al, Eur. Phys. J.C. 80 5, 452 (2020)
 [2]: M. Bleicher et al, J. Phys. G. 25, 1859 (1999)
 [3]: H. Xu et al, PRC 105, L011901 (2022)

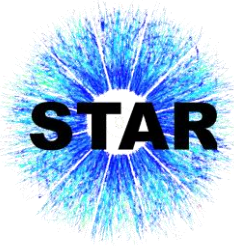

Conclusion

- Observed baryon stopping in γ +Au-rich collisions with a qualitatively comparable (possibly steeper) slope to hadronic Au+Au collisions.
- Ratio of baryon to charge number difference is observed to be larger than 1 using Ru+Ru and Zr+Zr collisions at $\sqrt{s_{NN}} = 200$ GeV.
- Both results disfavor the assertion that valence quarks carry the baryon number.
- *C.Y. Tsang acknowledges financial support from The Gordon and Betty Moore Foundation and the American Physical Society to present this work at the GHP 2023 workshop.*

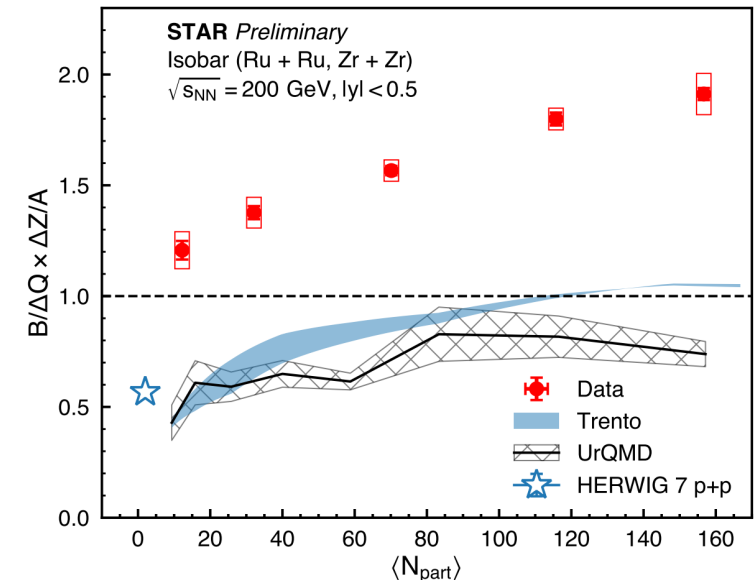
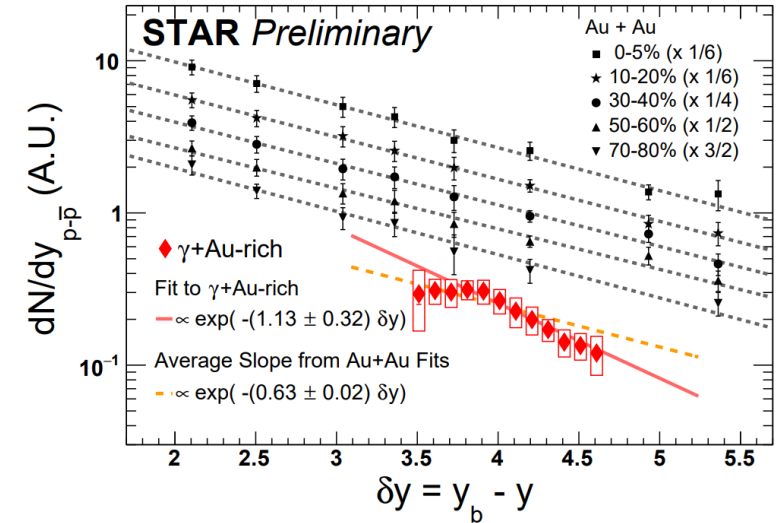

Backup slides

Enhanced proton stopping at low p_T

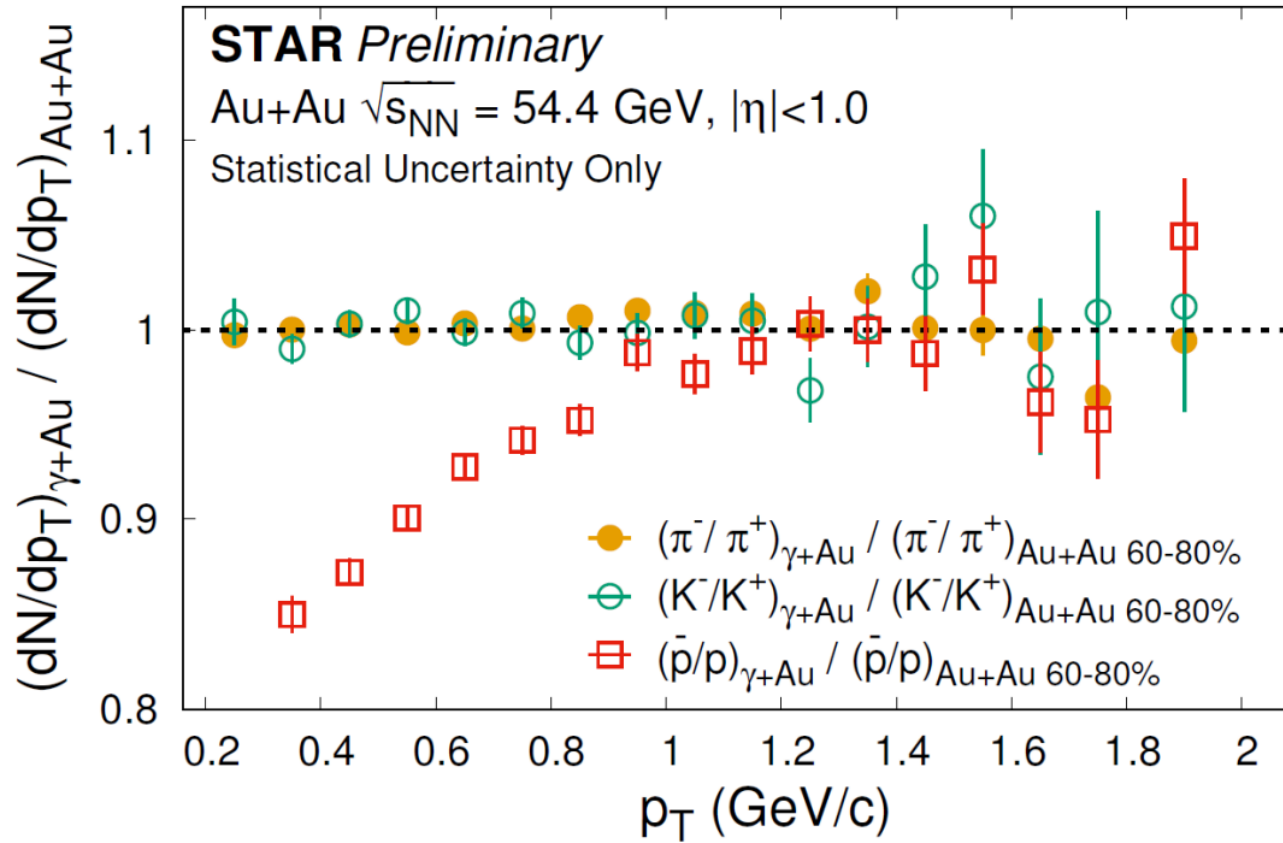

Not corrected for efficiency, but it's a double ratio



Particle spectra in γ +Au-rich sample

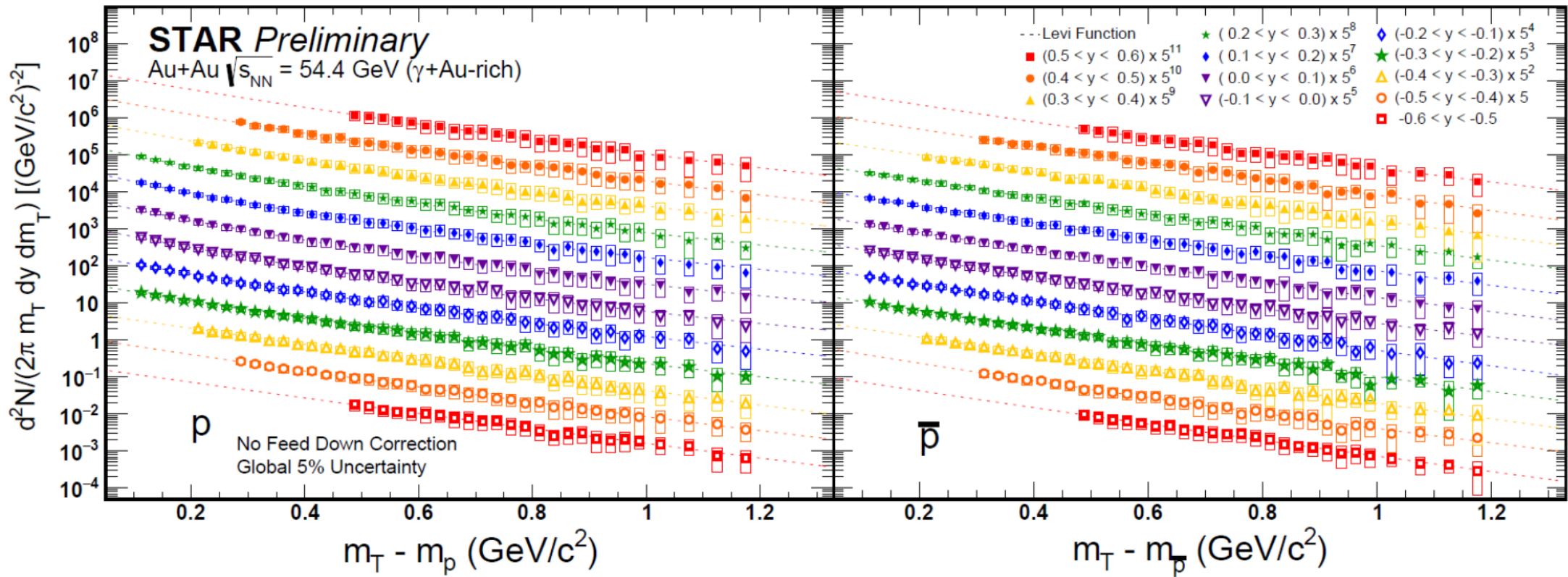

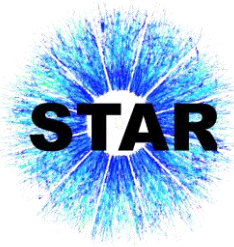

East going photon and west going photon cuts

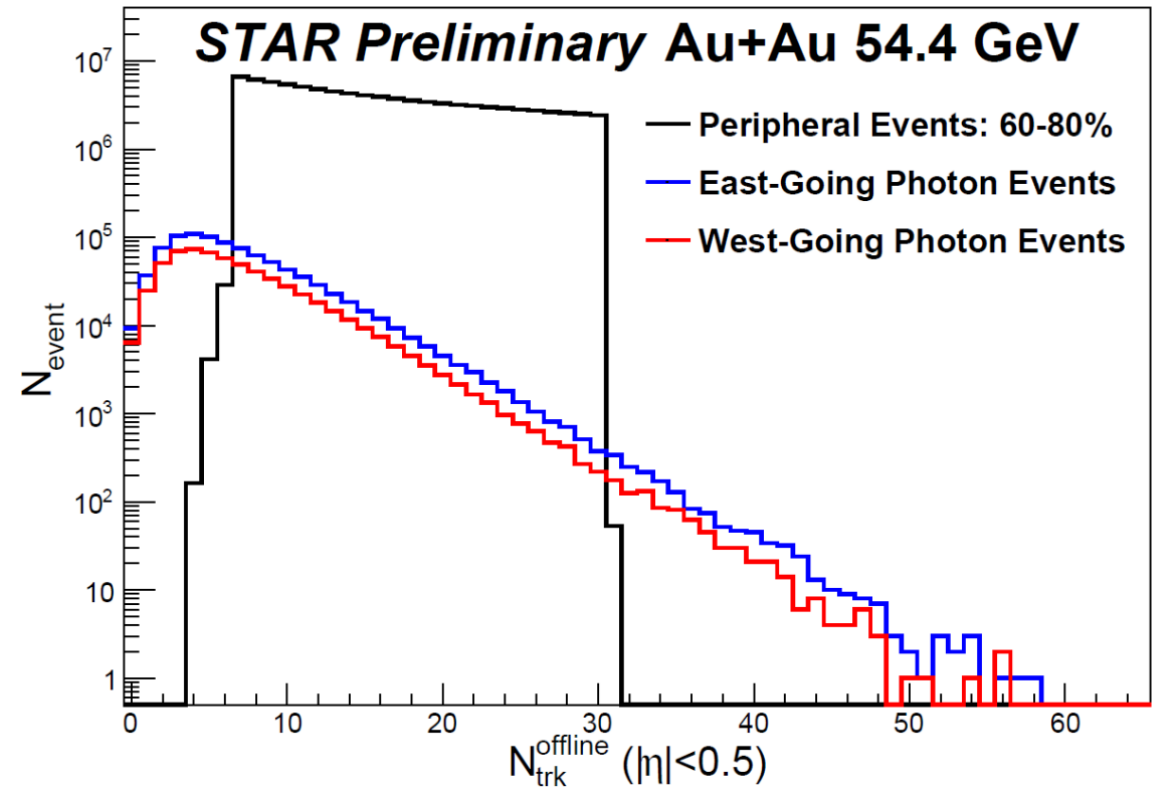
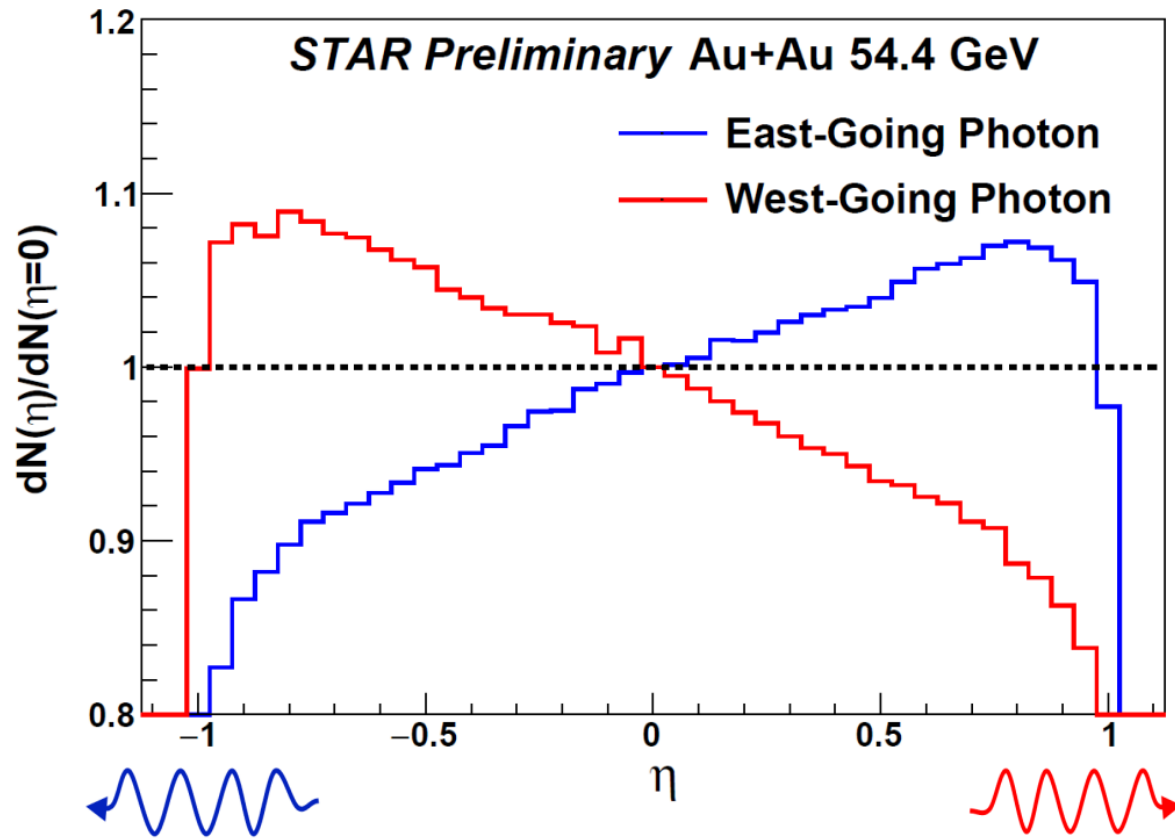
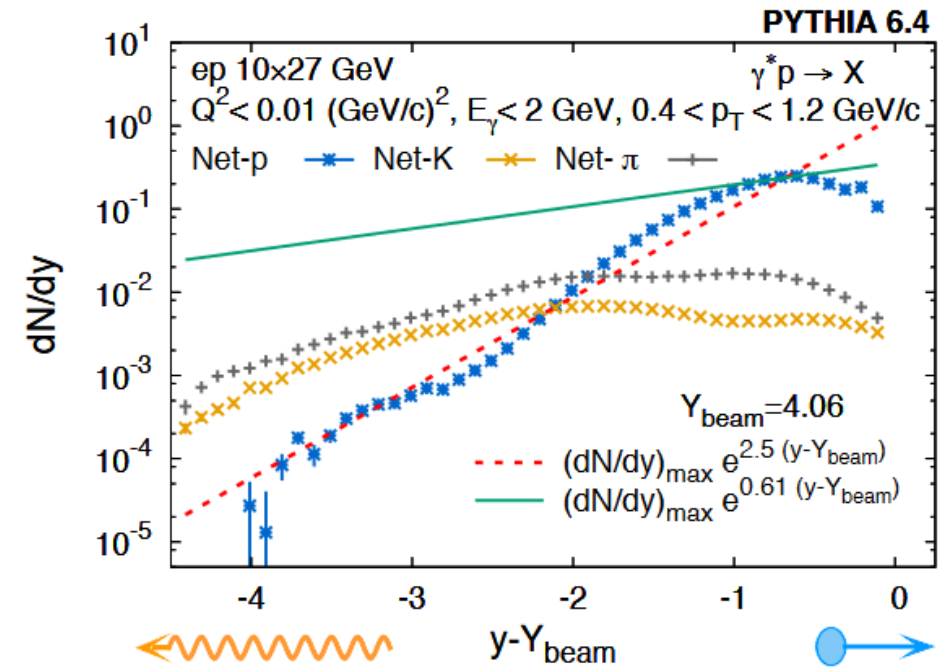
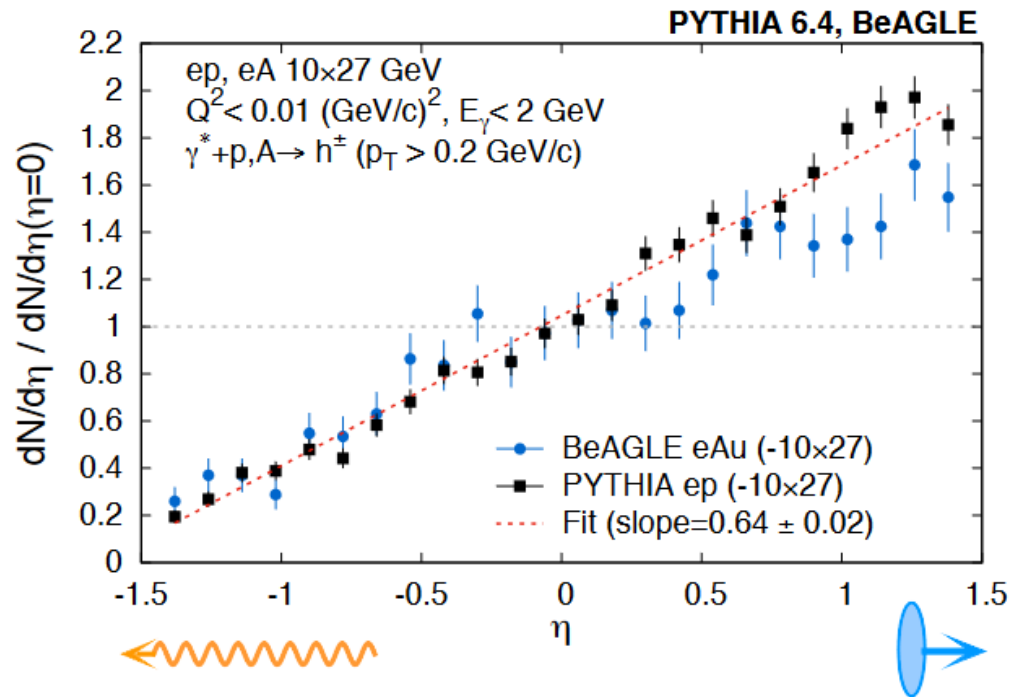
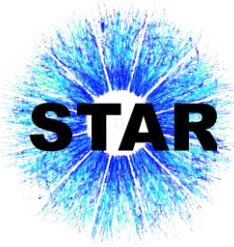
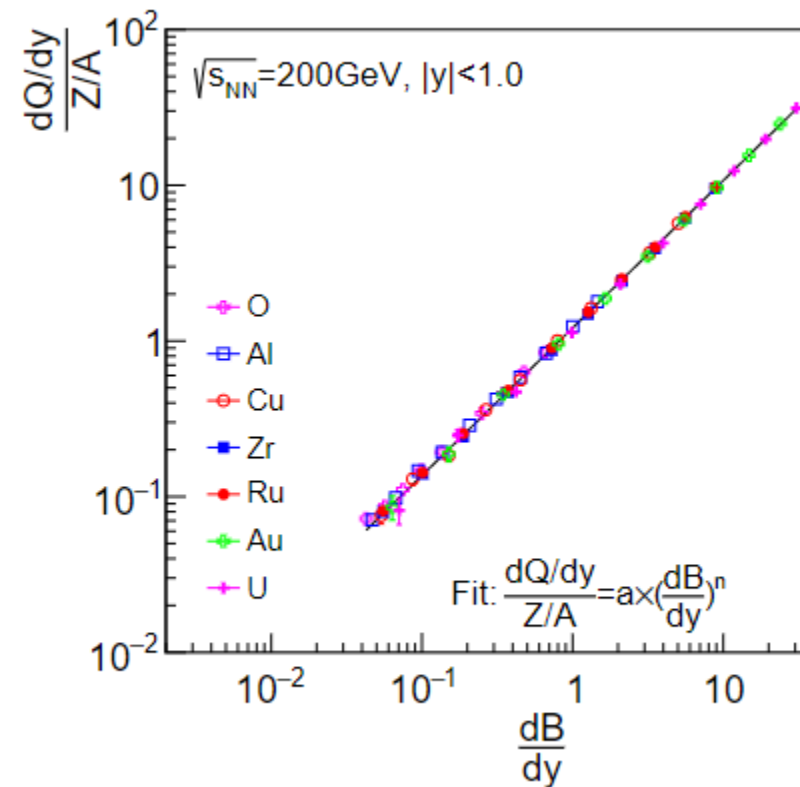

Figure from Ref. [3] comparing BeAGLE to PYTHIA





Baryon stopping v.s. charge stopping at $|y| < 1.0$, predicted by UrQMD



Courtesy: Z. Tang

Thank you