

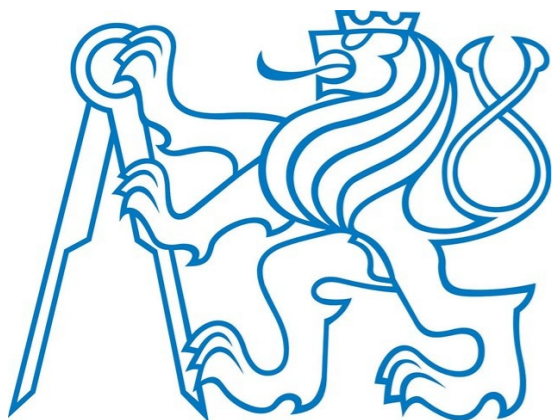

*The latest STAR
results on quarkonium
production*

*Barbara Trzeciak
for the STAR Collaboration
Czech Technical University in Prague*

Excited QCD
8 - 14 March, 2015
Tatranska Lomnica, Slovakia



INVESTMENTS IN EDUCATION DEVELOPMENT

Quarkonia at RHIC - Motivation



Charmonia: J/ψ , $\psi(2S)$, χ_C

Bottomonia: $\Upsilon(1S)$, $\Upsilon(2S)$, $\Upsilon(3S)$, χ_B

First ideas:

- ✓ **color screening** - quarkonium suppression in QGP in heavy-ion collisions

H. Satz, Nucl. Phys. A (783):249-260 (2007)



- ✓ **QGP thermometer** - suppression of different states is determined by T and their binding energies

Screening radius:

$$r_D(T) \propto 1/T$$

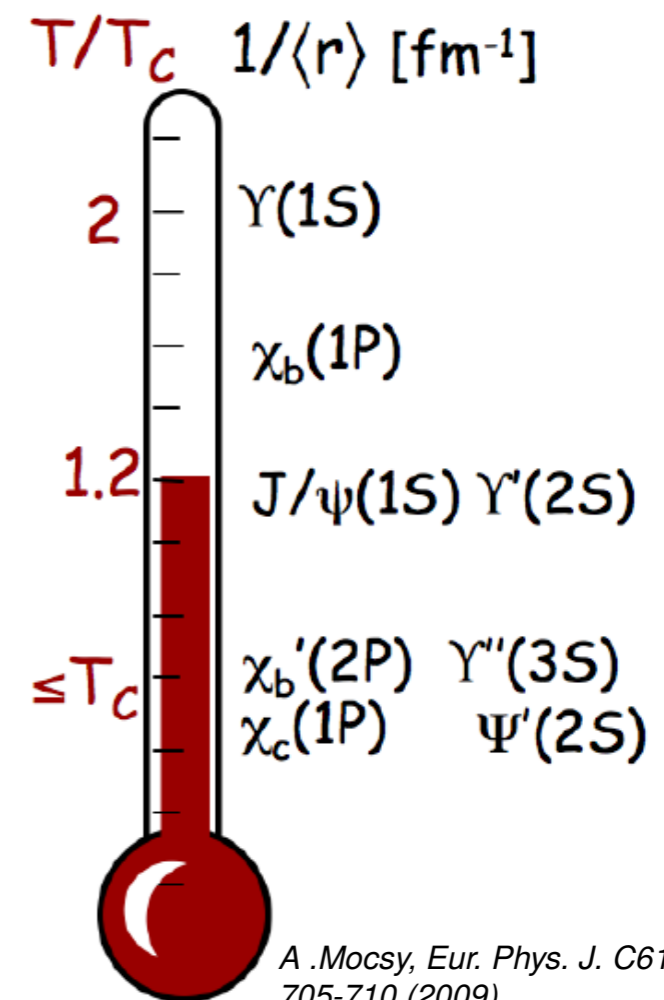

A. Mocsy, Eur. Phys. J. C61, 705-710 (2009)

Quarkonia - other effects

But there are additional complications:

- Still unclear **production mechanism** in elementary collisions
- **Feed-down:**
 - * prompt: direct J/ψ ($\sim 60\%$) + feed down from $\psi(2S)$ and χ_c ($\sim 40\%$);
 - * non-prompt: B-mesons feed-down (up to 25% at 12 GeV/c, Phys. Lett. B722 (2013) 55)
 - * $\sim 50\%$ of $\Upsilon(1S)$ originates from excited states feed-down (Phys. Rev. Lett. 84 (2000) 2094)
- **Cold Nuclear Matter (CNM) effects** - nuclear (anti-)shadowing, Cronin effect, nuclear absorption, ...
- Other **Hot Nuclear Matter effects** - regeneration, ...



➤ **High- p_T J/ψ and Υ - cleaner probes**

✓ High- p_T J/ψ - almost not affected by CNM effects and recombination

✓ Υ - negligible co-mover absorption and recombination

at RHIC: $\sigma_{cc} \sim 800\mu\text{b} \gg \sigma_{bb} \sim (1-2)\mu\text{b}$

✓ Energy dependence of quarkonium production - varying relative contributions

➤ **Measure quarkonia at different colliding systems and energies, in different kinematic regions**

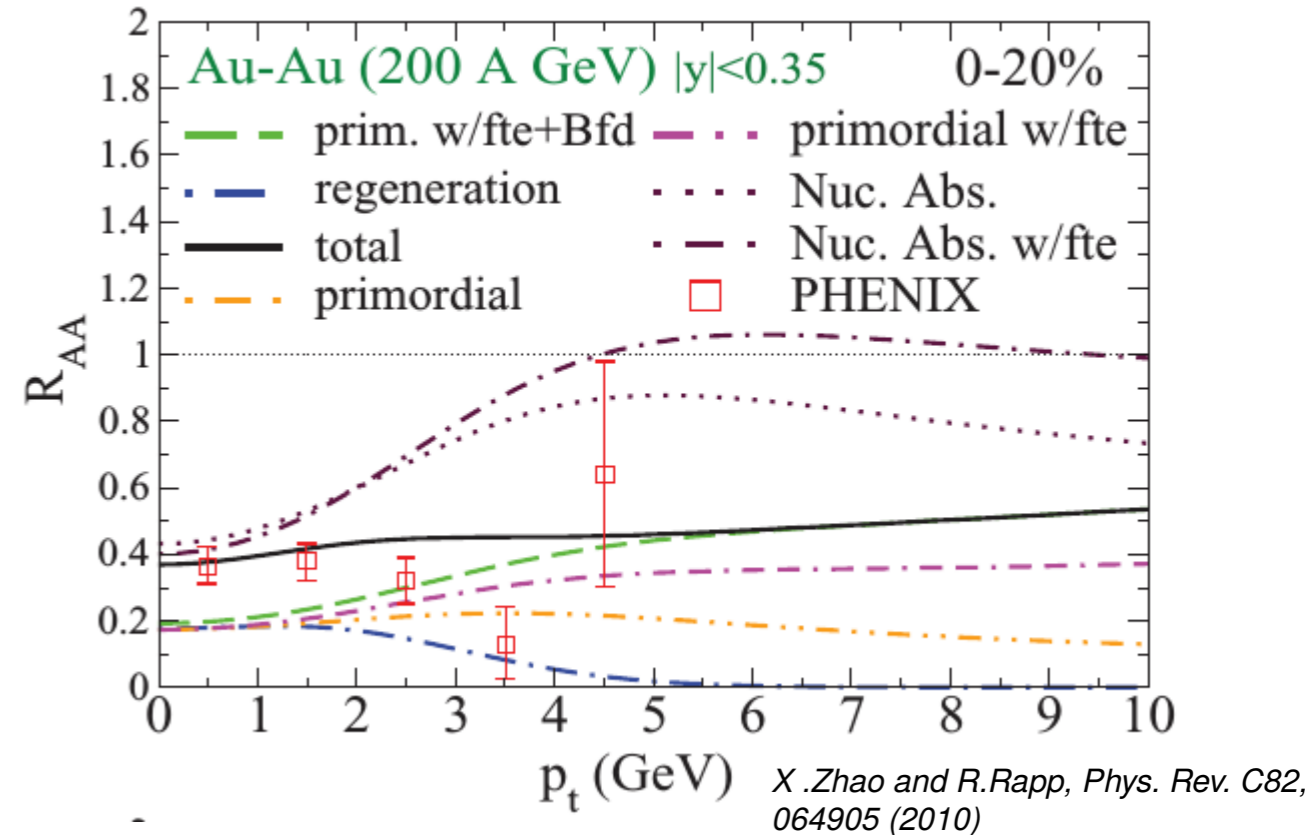

$$R_{AA} = \frac{1}{\langle N_{coll} \rangle} \frac{dN/dy^{A+A}}{dN/dy^{p+p}}$$

Quarkonia in the *STAR* Experiment

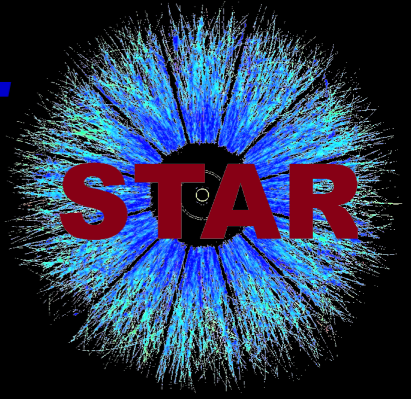

$$J/\psi / \Upsilon \rightarrow e^+ e^- (\mu^+ \mu^-)$$

$$|\eta| < 1, 0 < \phi < 2\pi$$

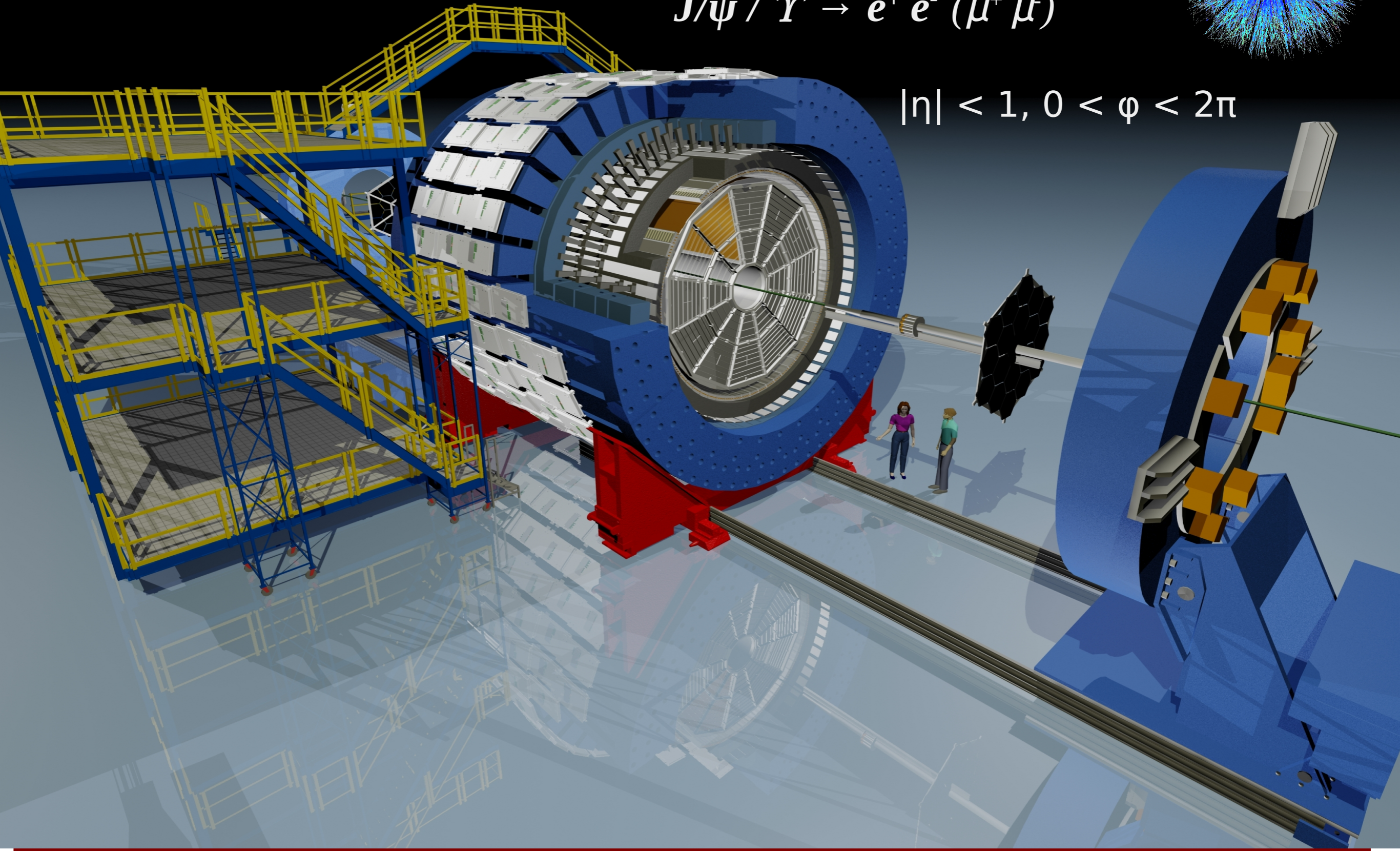

Quarkonia in the *STAR* Experiment

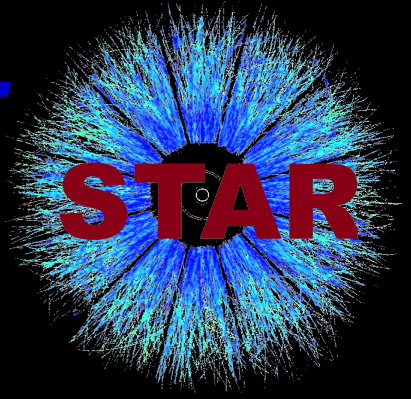

$$J/\psi / \Upsilon \rightarrow e^+ e^- (\mu^+ \mu^-)$$

$$|\eta| < 1, 0 < \phi < 2\pi$$

✓ VPD - minimum bias trigger

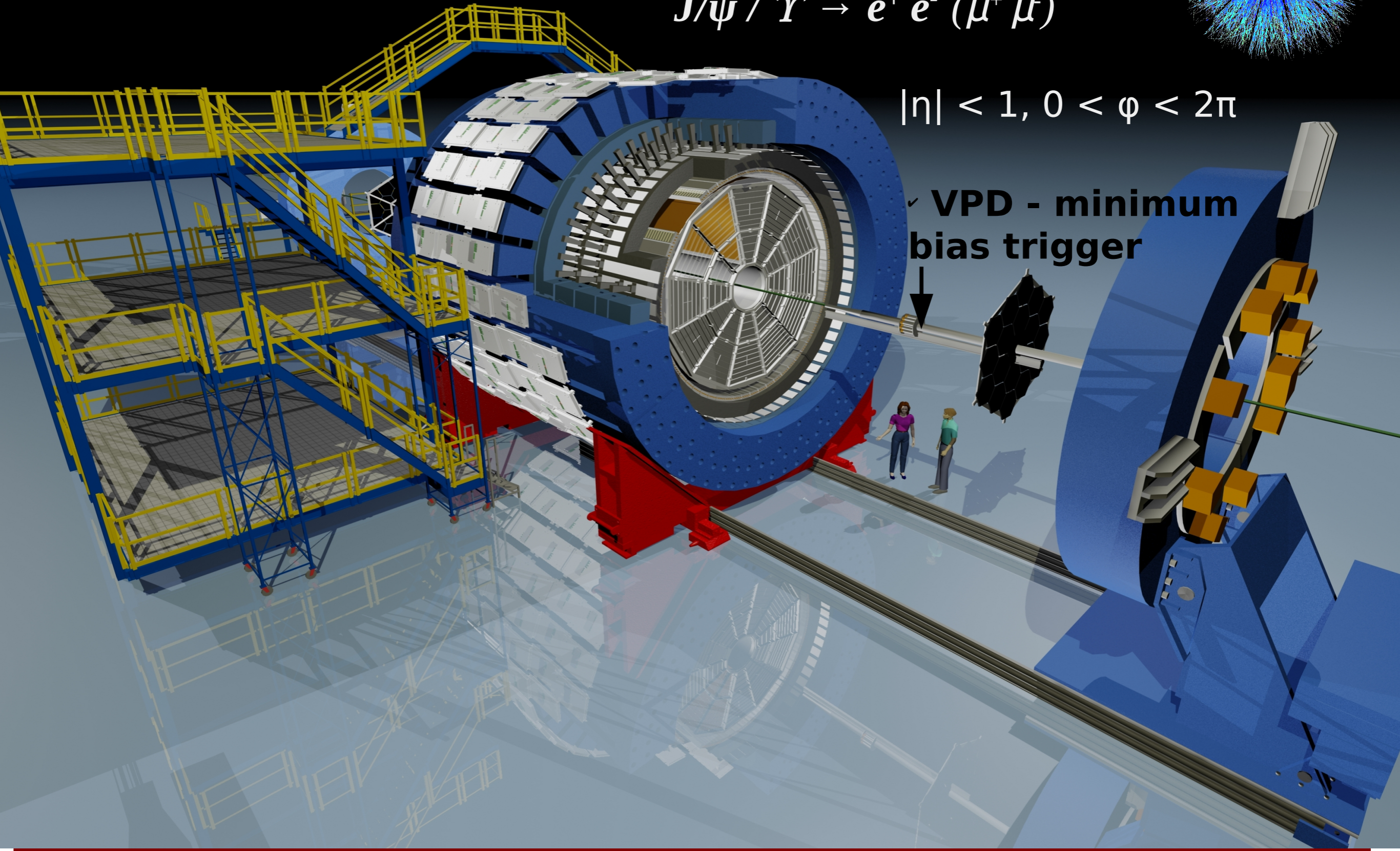

Quarkonia in the *STAR* Experiment

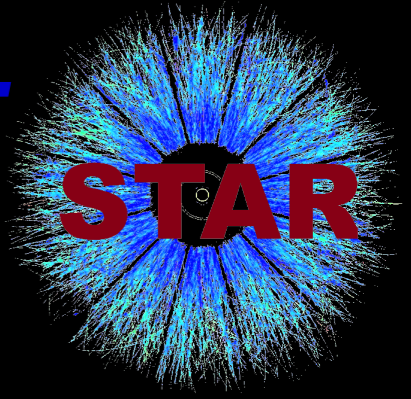

$$J/\psi / \Upsilon \rightarrow e^+ e^- (\mu^+ \mu^-)$$

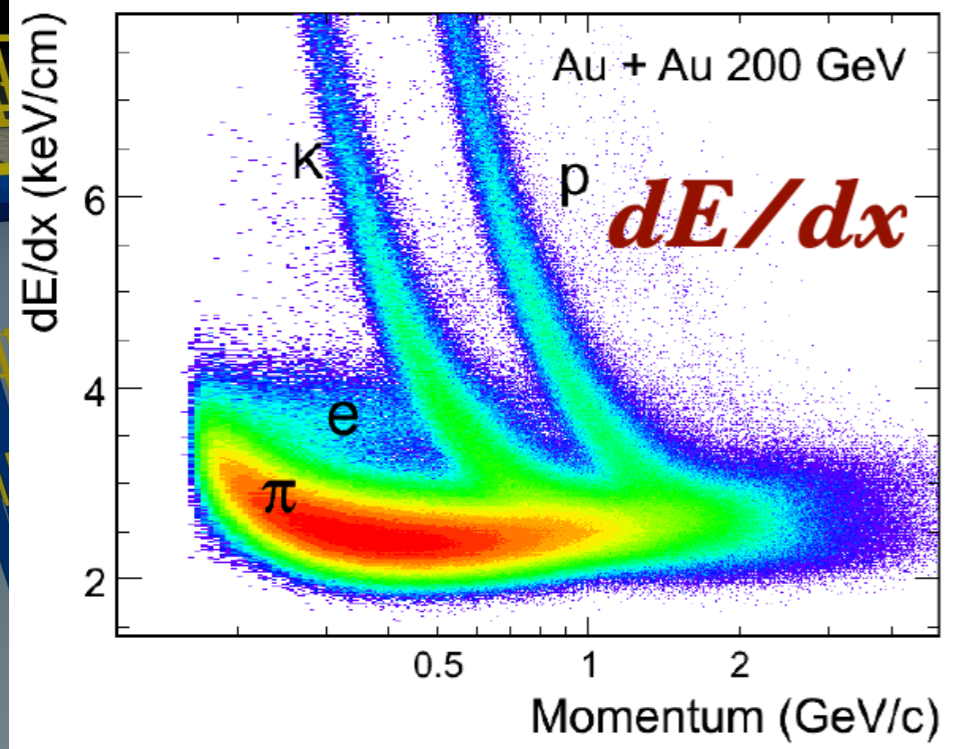

$$|\eta| < 1, 0 < \phi < 2\pi$$

✓ VPD - minimum bias trigger

✓ TPC - tracking, PID: dE/dx

Quarkonia in the *STAR* Experiment

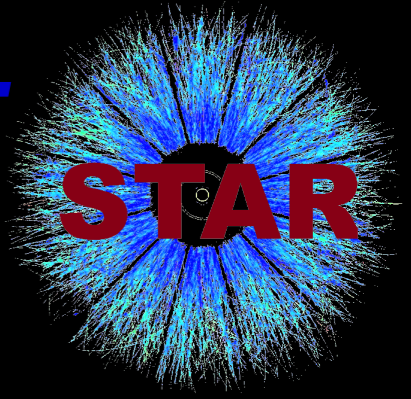

$$J/\psi / \Upsilon \rightarrow e^+ e^- (\mu^+ \mu^-)$$

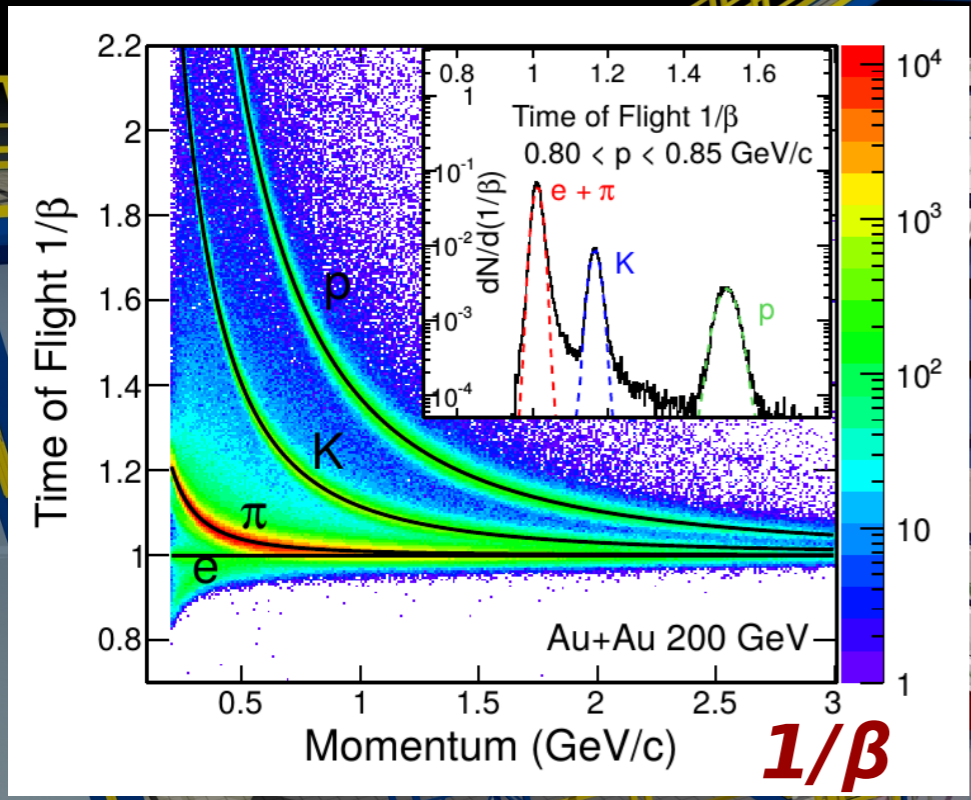

$$|\eta| < 1, 0 < \phi < 2\pi$$

✓ VPD - minimum bias trigger

✓ TPC - tracking, PID: dE/dx

✓ TOF - time resolution < 100 ps
PID: $1/\beta$

Quarkonia in the STAR Experiment

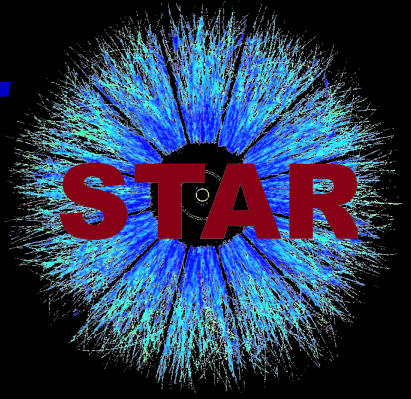

$$J/\psi / \Upsilon \rightarrow e^+ e^- (\mu^+ \mu^-)$$

$$|\eta| < 1, 0 < \phi < 2\pi$$

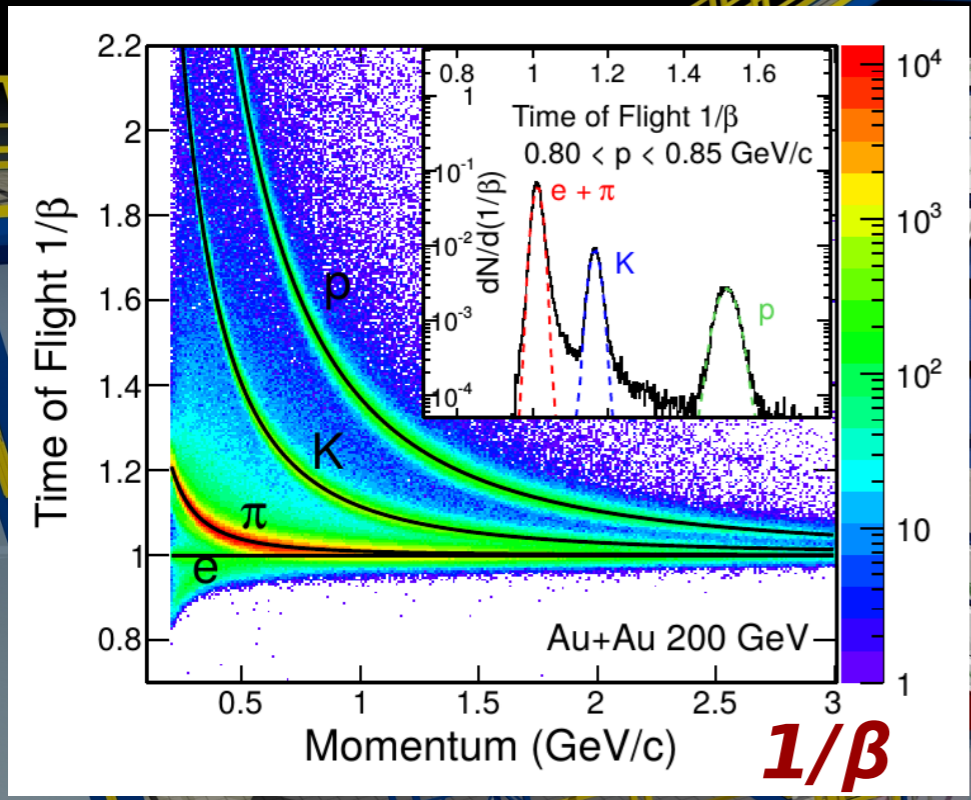

✓ TPC - tracking, PID: dE/dx

✓ TOF - time resolution < 100 ps
 PID: $1/\beta$

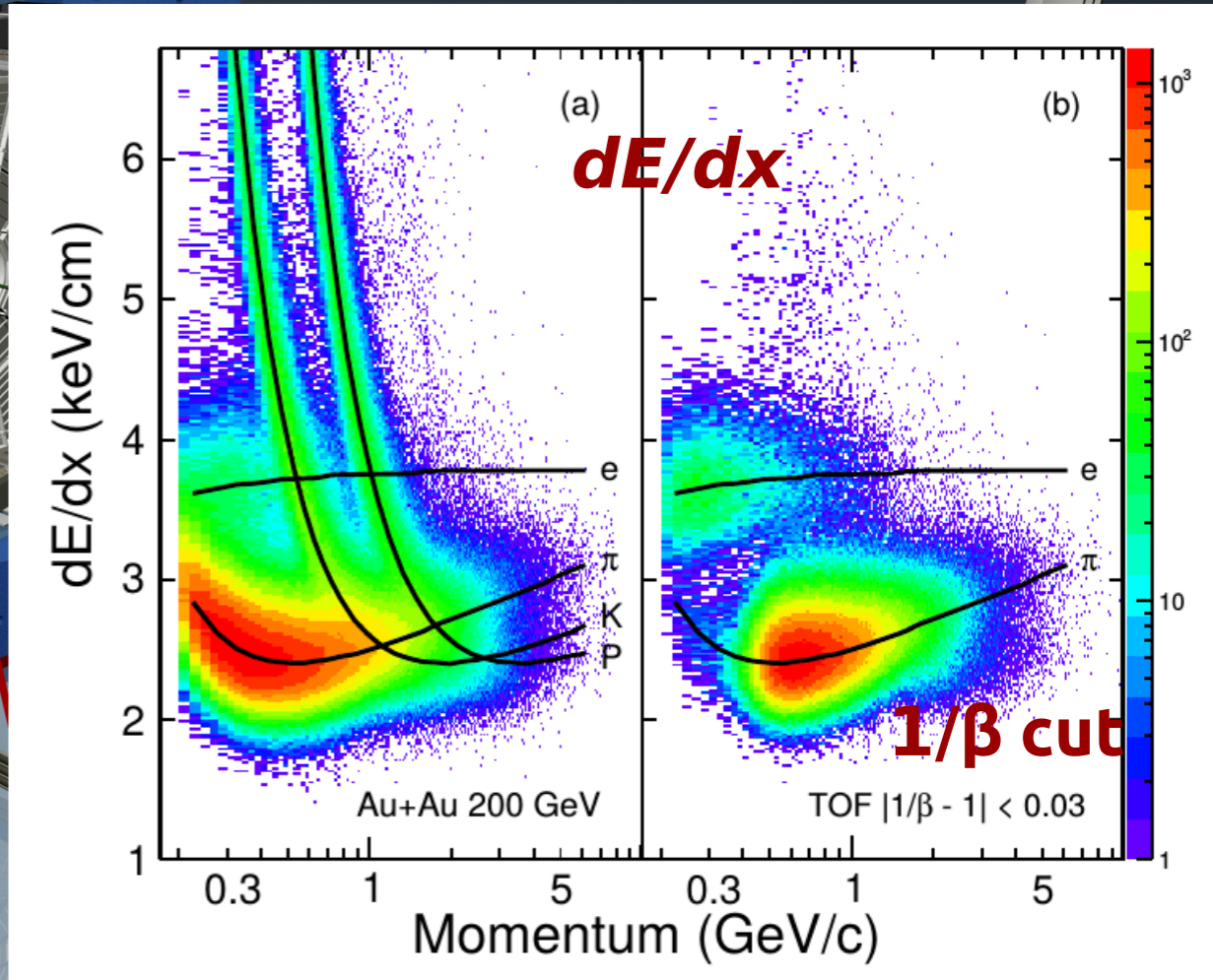

Quarkonia in the STAR Experiment

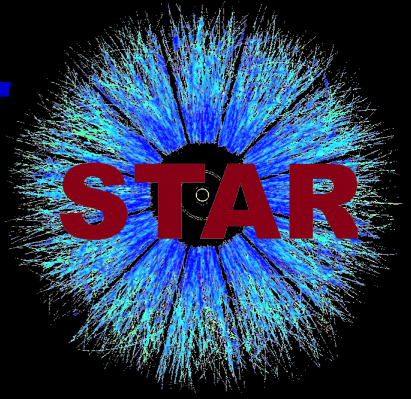

$$J/\psi / \Upsilon \rightarrow e^+ e^- (\mu^+ \mu^-)$$

$$|\eta| < 1, 0 < \phi < 2\pi$$

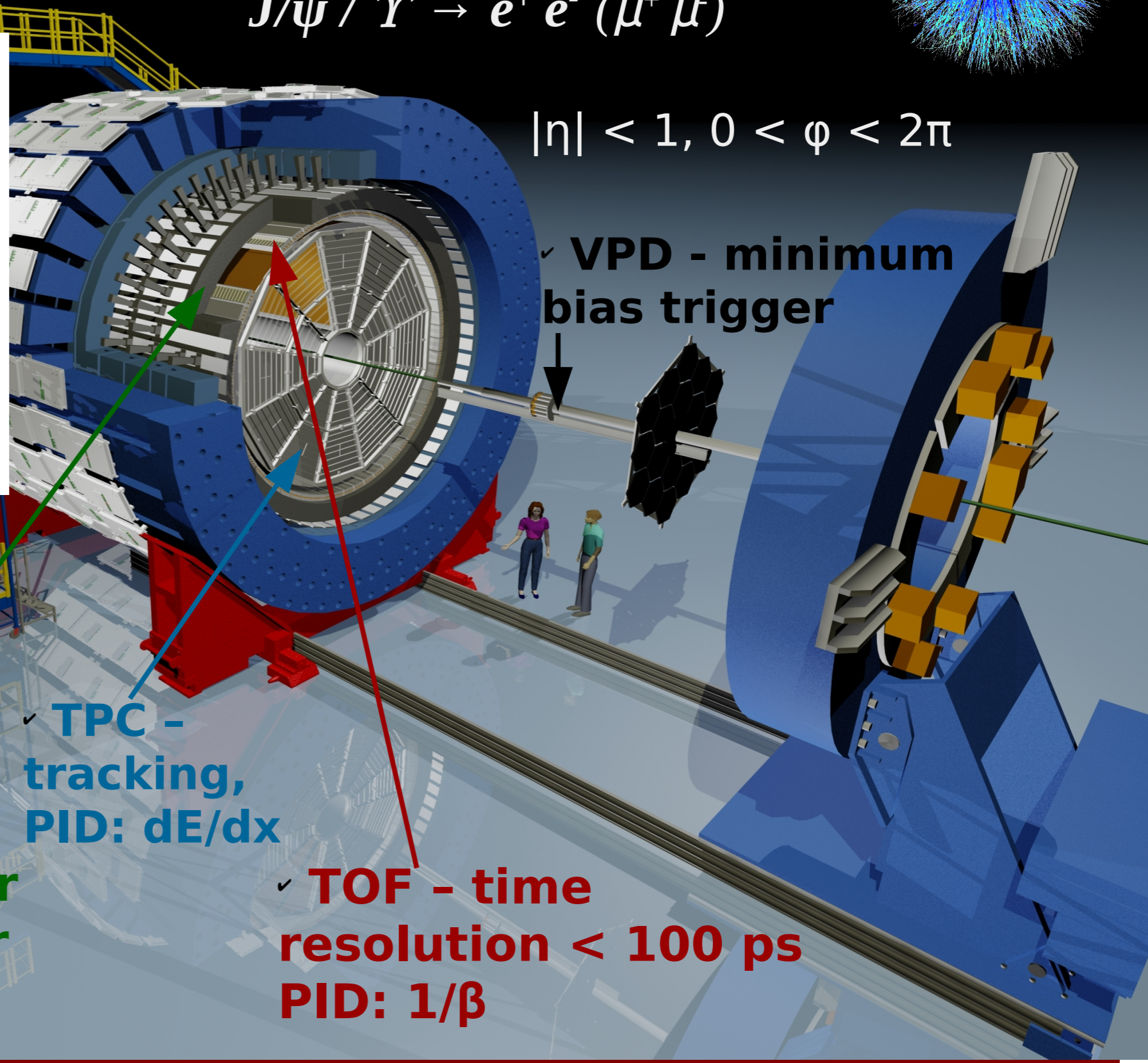
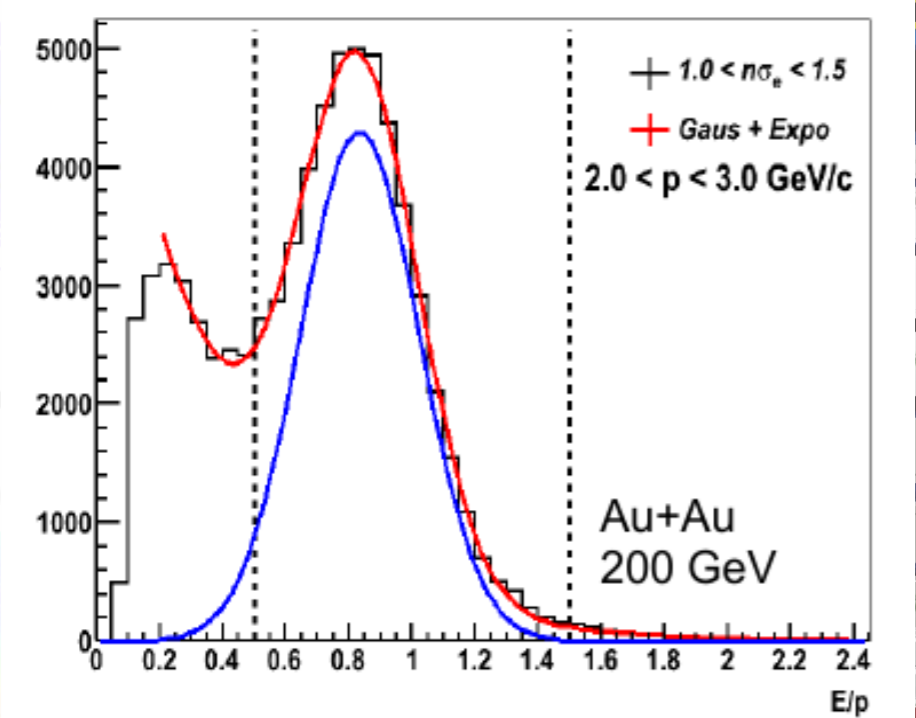

✓ VPD - minimum bias trigger

✓ TPC - tracking, PID: dE/dx

✓ BEMC - trigger
PID: E/p (~ 1 for electron)

✓ TOF - time resolution < 100 ps
PID: $1/\beta$

Quarkonia in the *STAR* Experiment

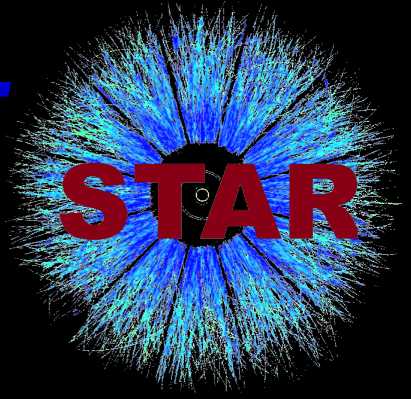

$$J/\psi / \Upsilon \rightarrow e^+ e^- (\mu^+ \mu^-)$$

$$|\eta| < 1, 0 < \phi < 2\pi$$

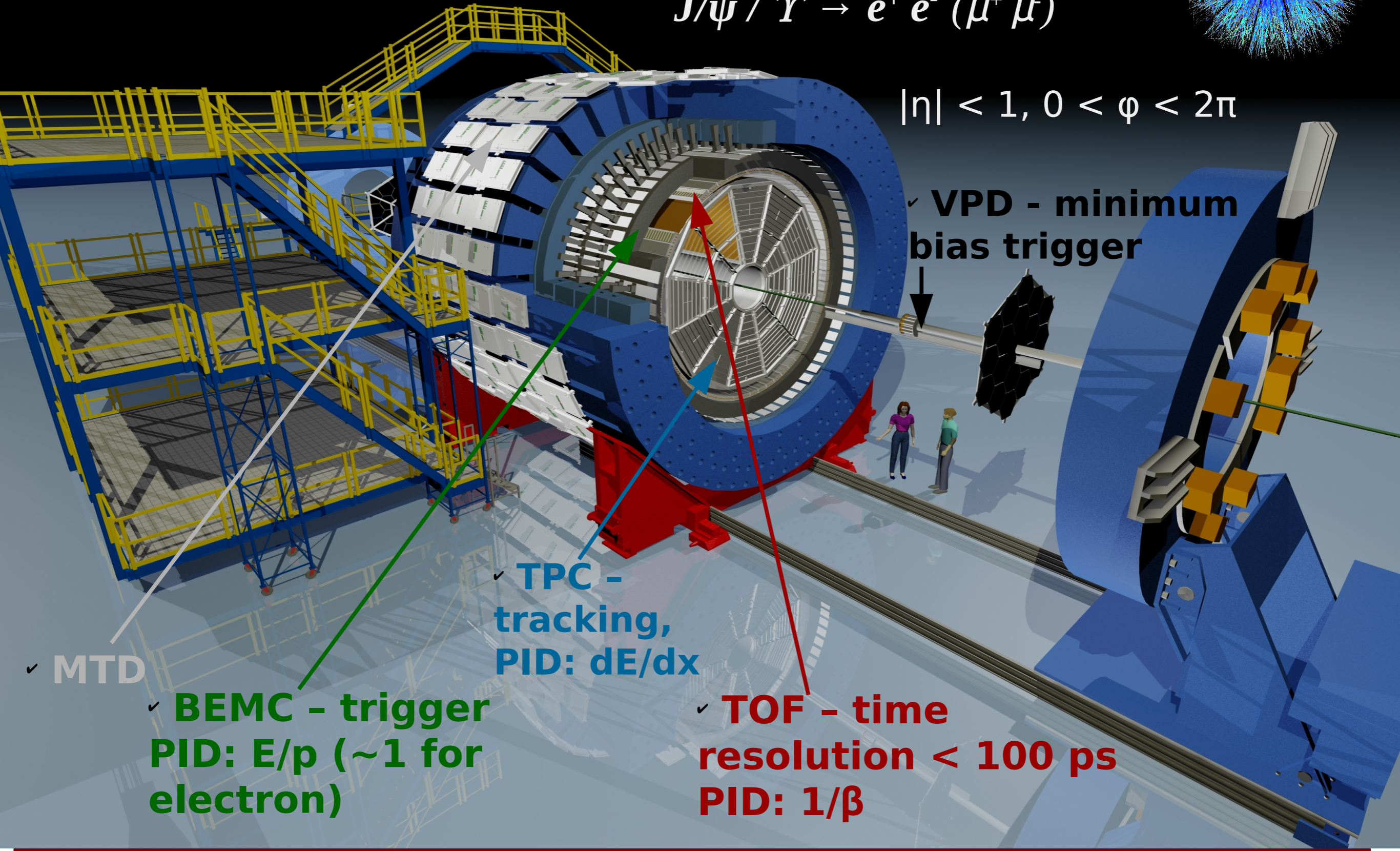

✓ MTD

✓ BEMC - trigger
PID: E/p (~ 1 for electron)

✓ TPC - tracking,
PID: dE/dx

✓ TOF - time resolution < 100 ps
PID: $1/\beta$

✓ VPD - minimum bias trigger

Quarkonia in the *STAR* Experiment

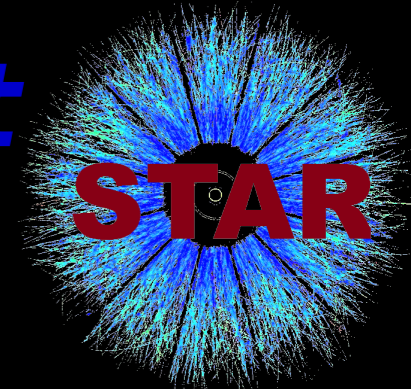

$$J/\psi / \Upsilon \rightarrow e^+ e^- (\mu^+ \mu^-)$$

$$|\eta| < 1, 0 < \phi < 2\pi$$

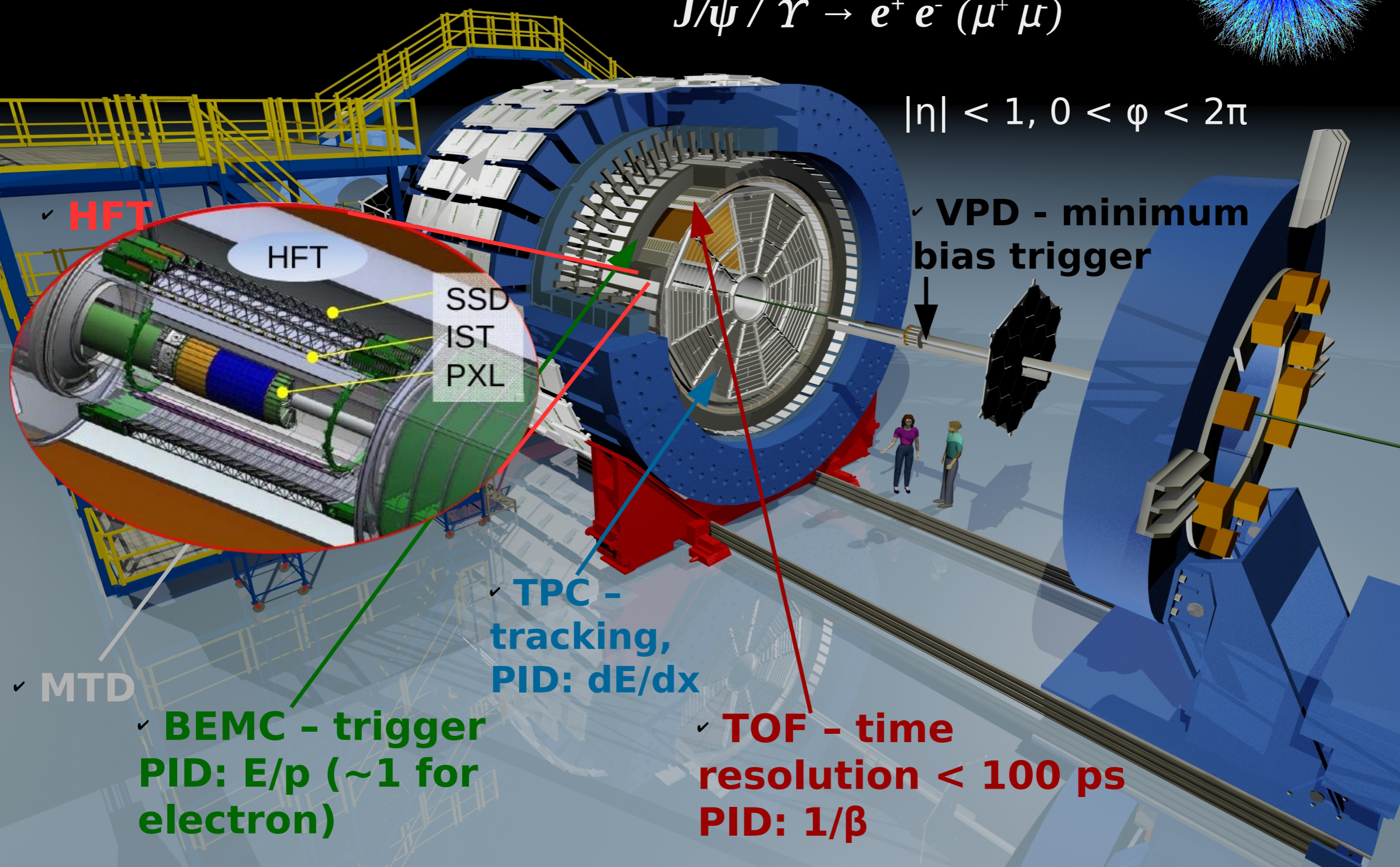

✓ **HFT**

HFT

SSD
IST
PXL

✓ **VPD - minimum bias trigger**

✓ **TPC - tracking, PID: dE/dx**

✓ **MTD**

✓ **BEMC - trigger
PID: E/p (~ 1 for electron)**

✓ **TOF - time resolution < 100 ps
PID: $1/\beta$**

J/ψ p_T spectrum in $p+p$



200 GeV

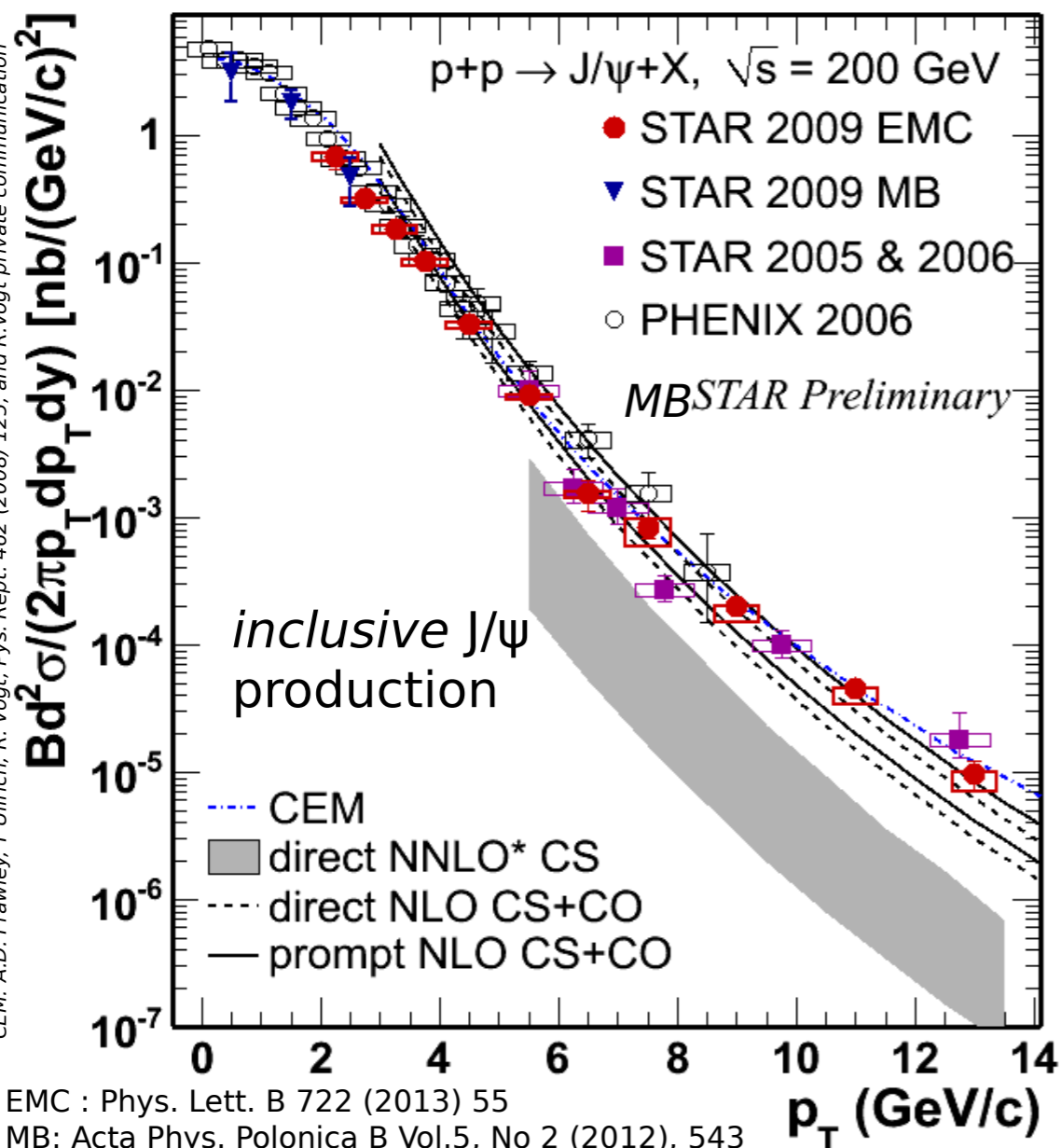

STAR EMC : Phys. Lett. B 722 (2013) 55
 STAR MB: Acta Phys. Polonica B Vol.5, No 2 (2012), 543

✓ Different models can reasonably well describe data at 200 GeV

500 GeV

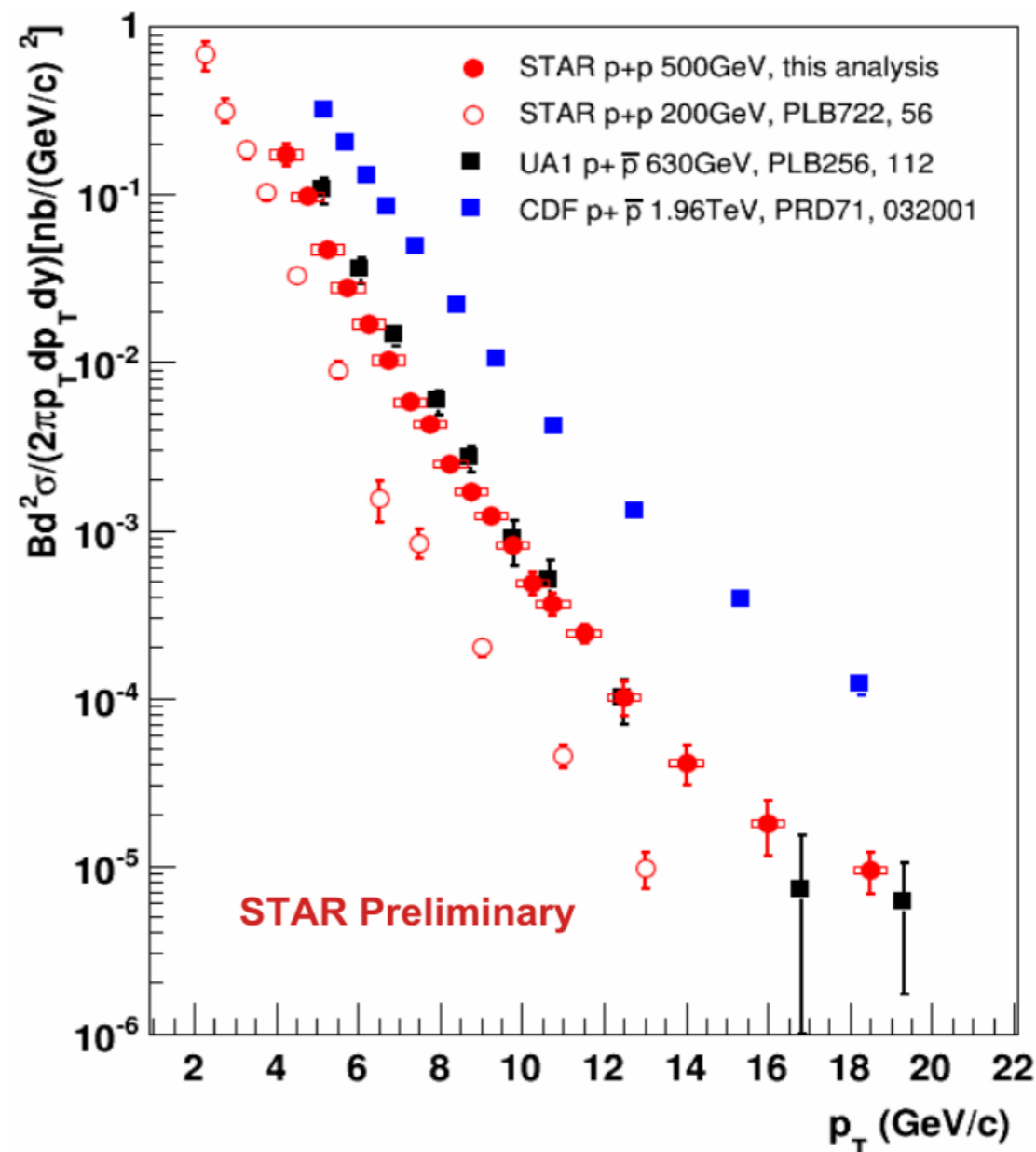

✓ Precise J/ψ measurement at new center of mass energy of 500 GeV, up to $p_T = 20$ GeV/c

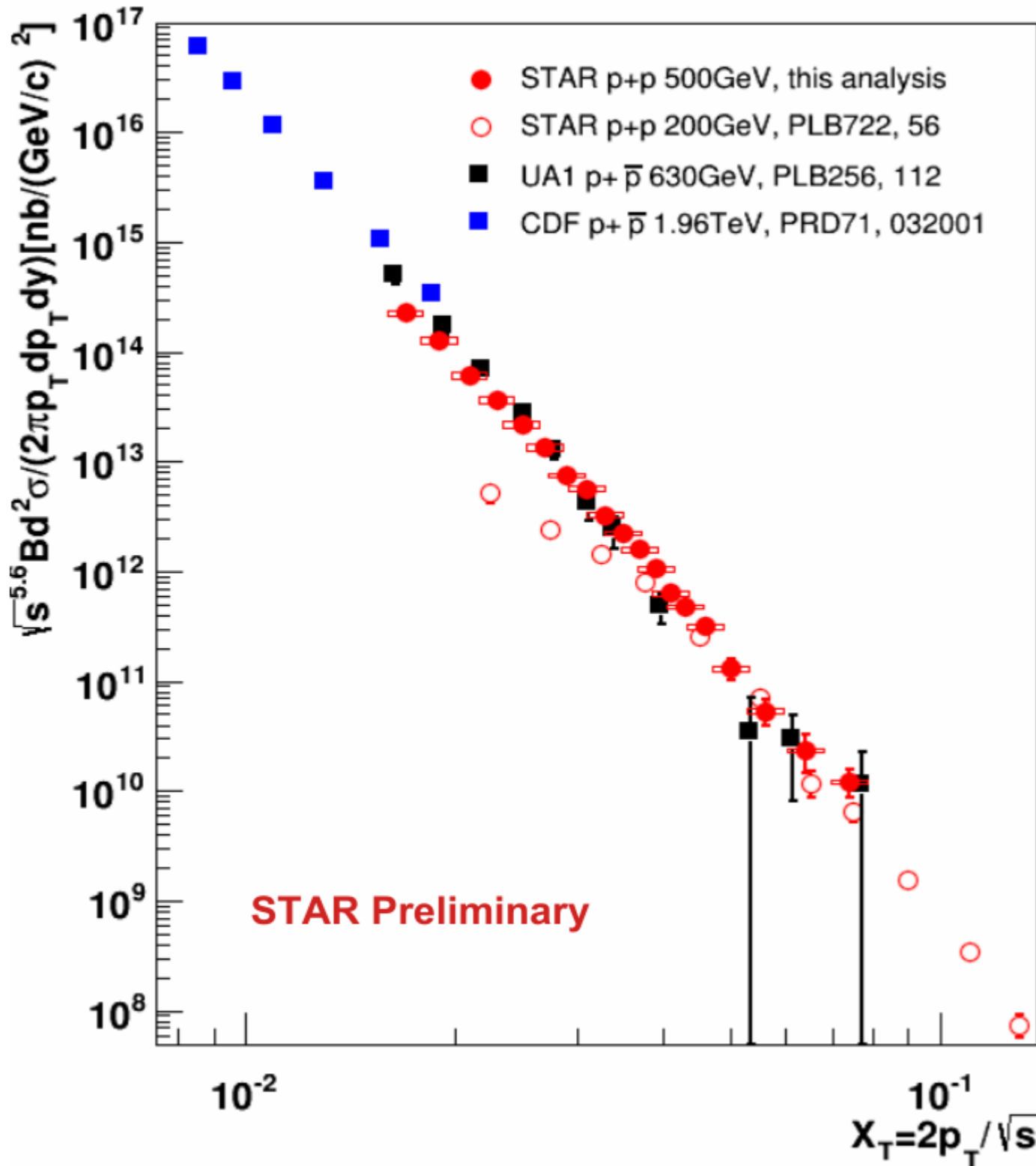

$$\frac{d^2\sigma}{2\pi p_T dp_T dy} = g(x_T) / (\sqrt{s})^n$$

✓ In p+p 200 GeV J/ψ production follows the x_T scaling of cross-section at mid-rapidity at high p_T , with $n = 5.6 \pm 0.2$ (Phys. Rev. C 80, 041902 (2009))

✓ x_T scaling observed also in 500 GeV data

→ x_T scaling breaking - transition from hard to soft process

n - number of constituents taking an active role in hadron production

$\psi(2S)$ in $p+p$ 500 GeV

- Constrain $\psi(2S)$ feed-down contribution to inclusive J/ψ production

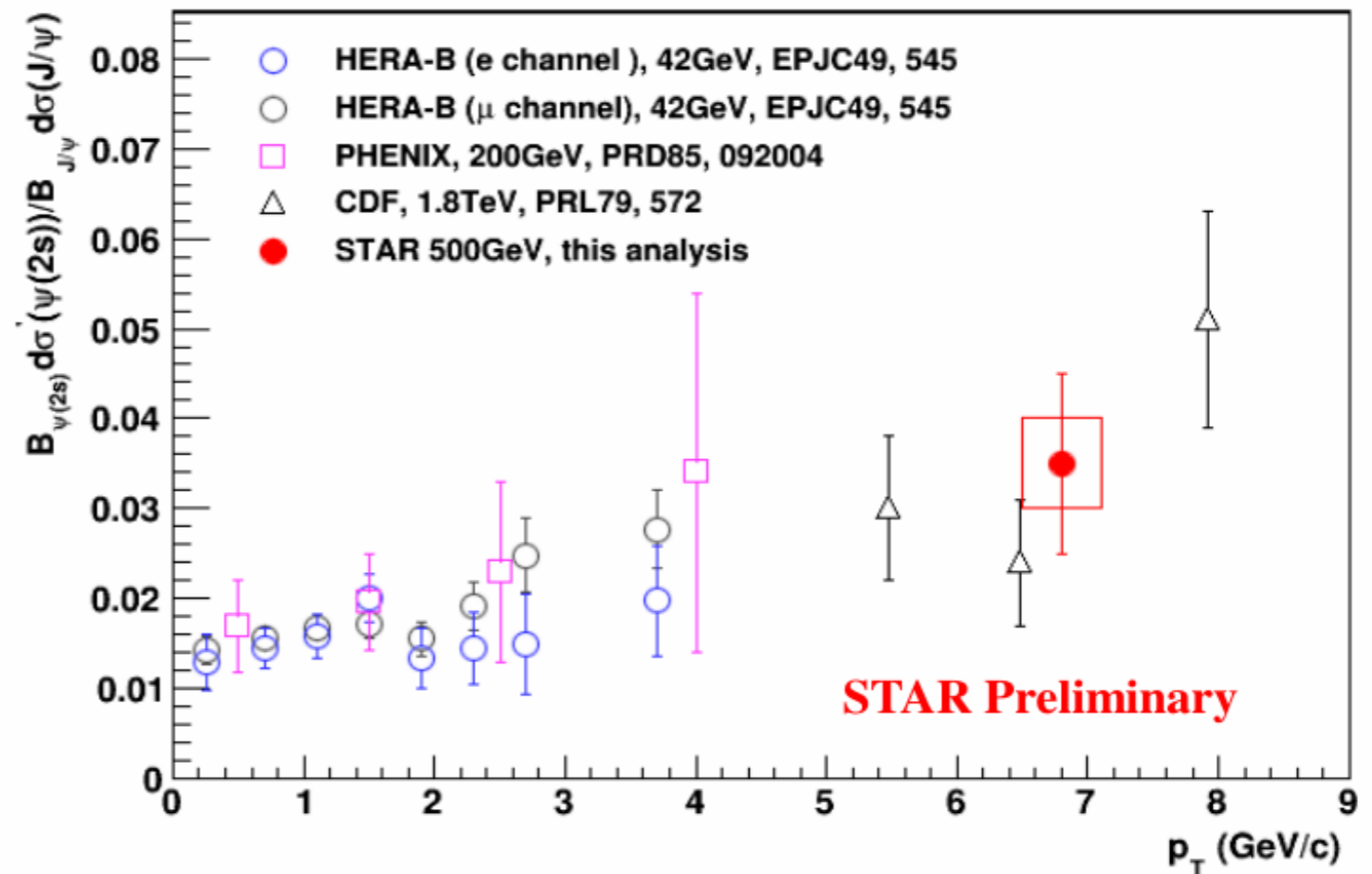
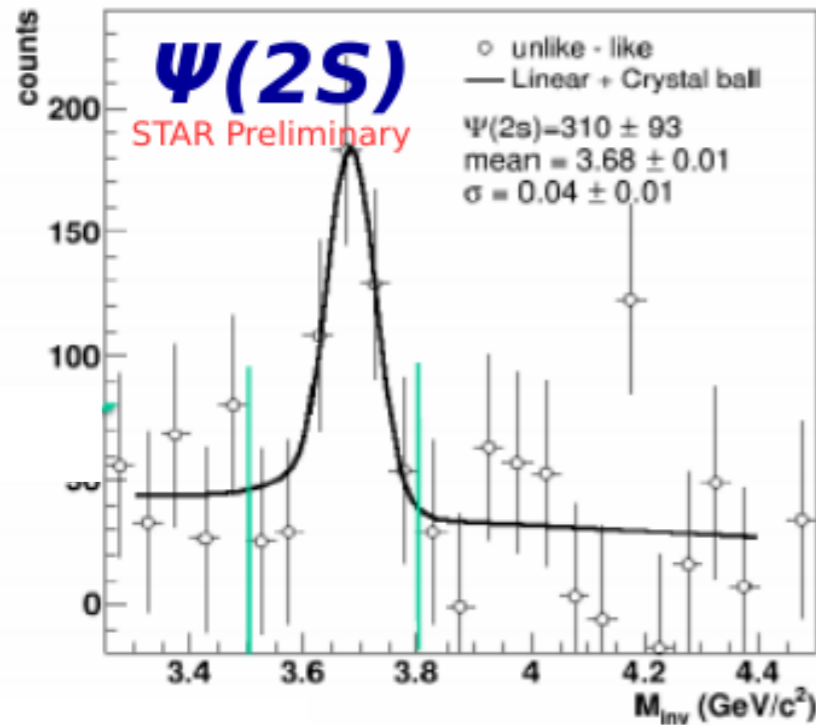

- ✓ First measurement of $(\psi(2S) / J/\psi)$ ratio in $p+p$ at 500 GeV
 - Consistent with other experiments
 - No collision energy dependence observed

J/ψ v_2 in Au+Au 200 GeV

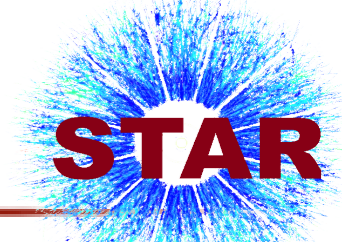

- ✓ J/ψ v_2 is consistent with zero at $p_T > 2$ GeV/c
- Disfavors the model with J/ψ production via thermalized (anti-)charm coalescence

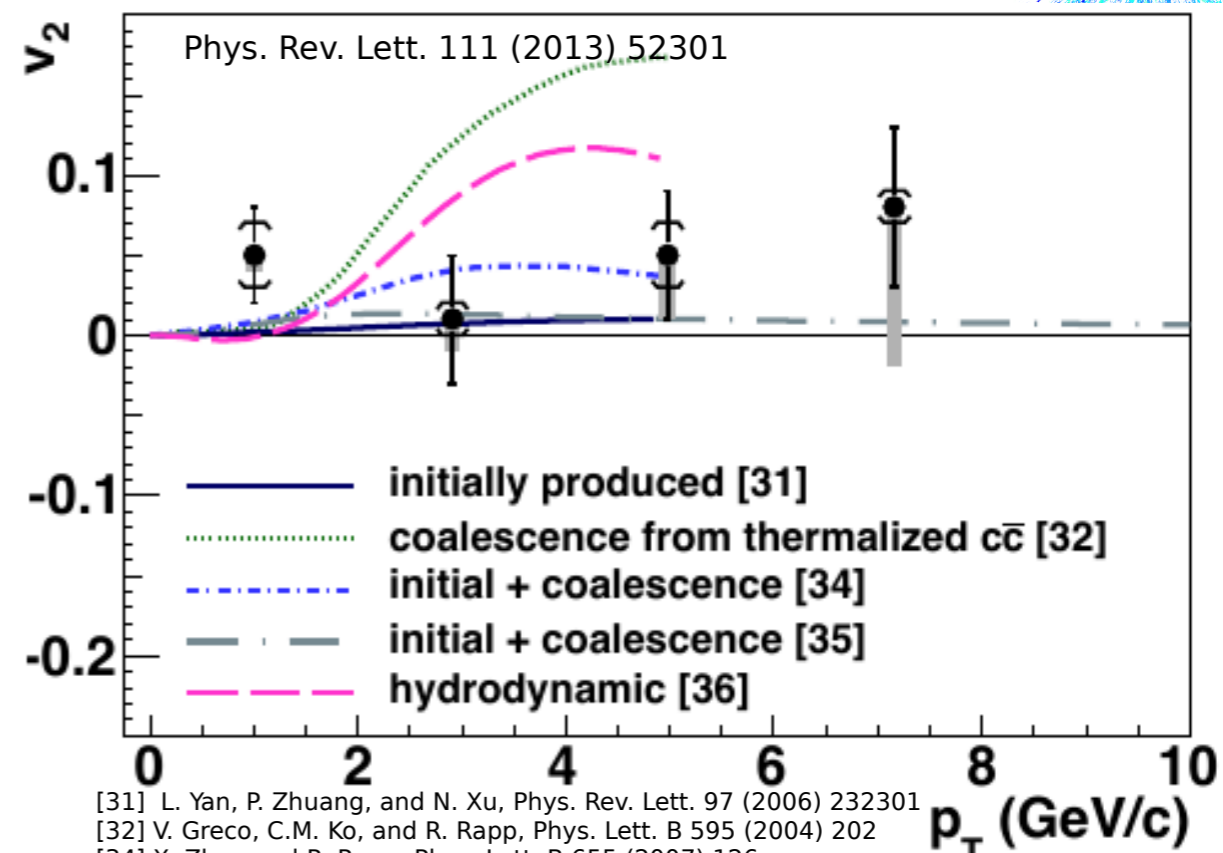

[31] L. Yan, P. Zhuang, and N. Xu, Phys. Rev. Lett. 97 (2006) 232301
[32] V. Greco, C.M. Ko, and R. Rapp, Phys. Lett. B 595 (2004) 202
[34] X. Zhao and R. Rapp, Phys. Lett. B 655 (2007) 126
[35] Y. Liu, N. Xu, and P. Zhuang, Nucl. Phys. A 834 (2010) 317c
[36] U. W. Heinz and C. Chen, private communication (2012)

J/ψ v_2 and p_T spectra in Au+Au 200 GeV

- ✓ J/ψ v_2 is consistent with zero at $p_T > 2$ GeV/c
- Disfavors the model with J/ψ production via thermalized (anti-)charm coalescence

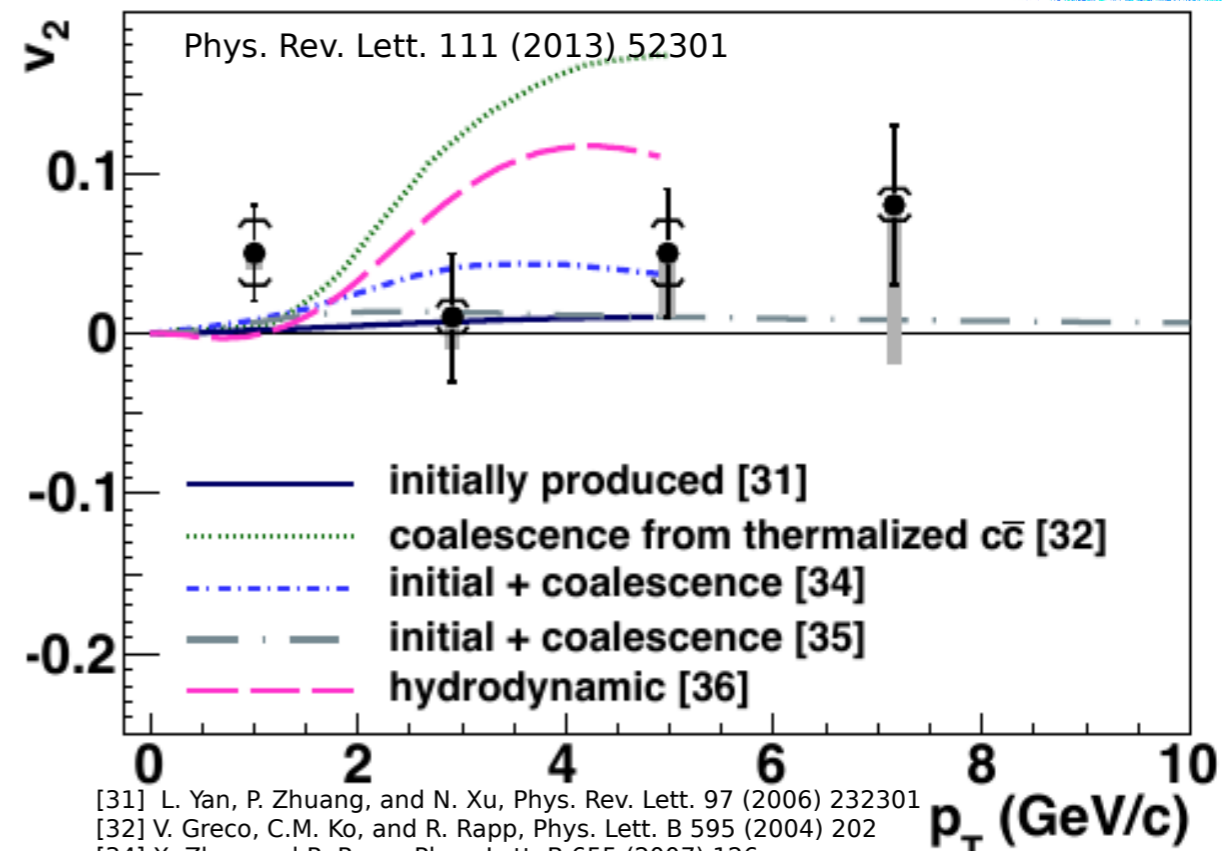
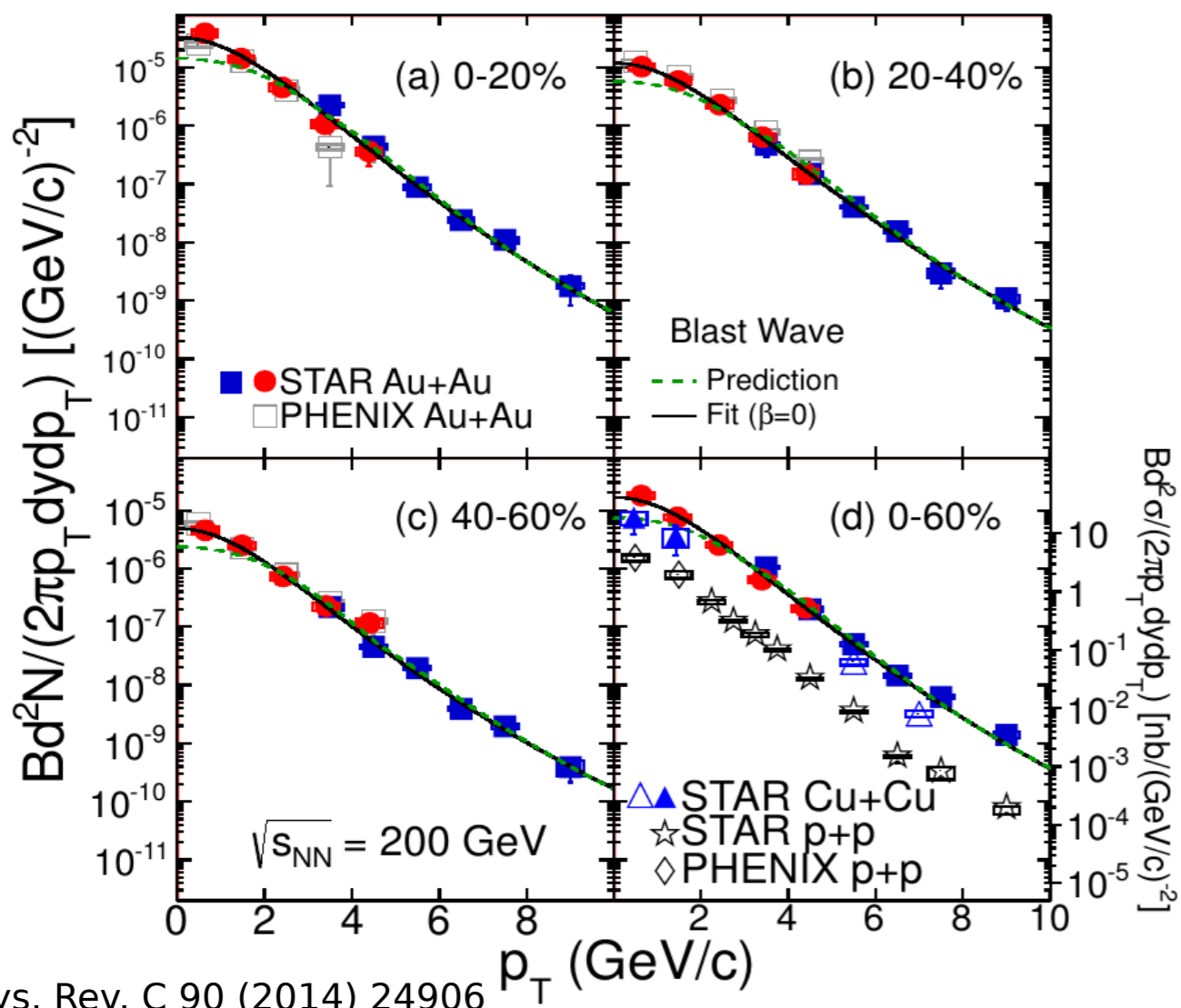

- [31] L. Yan, P. Zhuang, and N. Xu, Phys. Rev. Lett. 97 (2006) 232301
- [32] V. Greco, C.M. Ko, and R. Rapp, Phys. Lett. B 595 (2004) 202
- [34] X. Zhao and R. Rapp, Phys. Lett. B 655 (2007) 126
- [35] Y. Liu, N. Xu, and P. Zhuang, Nucl. Phys. A 834 (2010) 317c
- [36] U. W. Heinz and C. Chen, private communication (2012)

- ✓ At low p_T J/ψ spectra softer than the *TBW* prediction from light hadron
- small radial flow ?
- regeneration at low p_T ?

$J/\psi R_{AA}$ in Au+Au 200 GeV

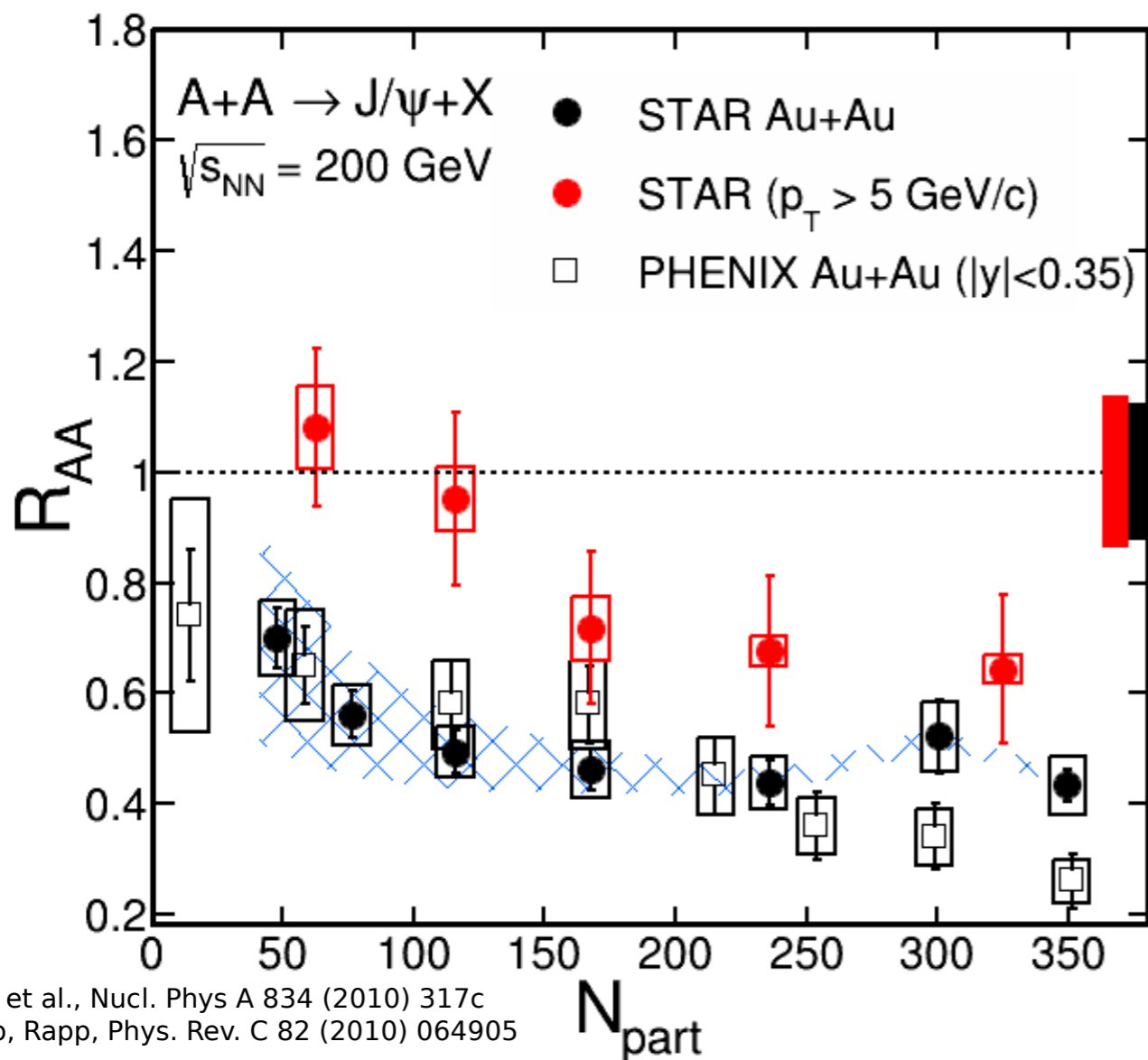

- ✓ Suppression increases with collision centrality
- ✓ High- p_T R_{AA} is systematically higher
 - J/ψ at high- p_T almost not affected by CNM effects and recombination *X. Zhao and R. Rapp, Phys. Rev. C82, 064905 (2010)*
- ✓ High- p_T J/ψ suppressed in central collisions
 - May indicate QGP effects

Y.Liu et al., Nucl. Phys A 834 (2010) 317c
 Zhao, Rapp, Phys. Rev. C 82 (2010) 064905

STAR high- p_T : Phys. Lett. B 722 (2013) 55
 STAR low- p_T : Phys. Rev. C 90 (2014) 24906

$$R_{AA} = \frac{1}{\langle N_{coll} \rangle} \frac{dN/dy^{A+A}}{dN/dy^{p+p}}$$

$J/\psi R_{AA}$ in Au+Au 200 GeV

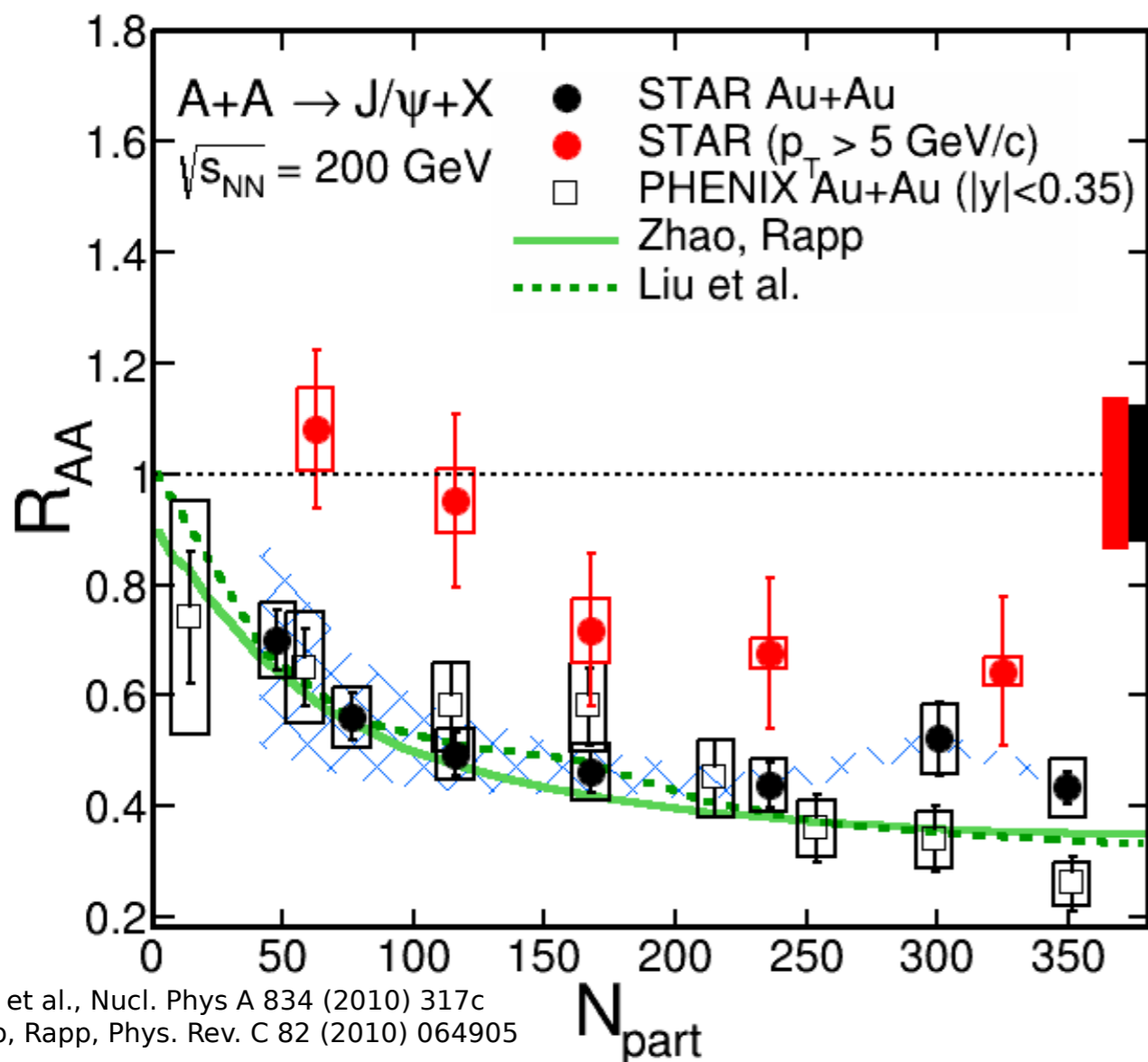

- ✓ Suppression increases with collision centrality
- ✓ High- p_T R_{AA} is systematically higher
- High- p_T J/ψ suppressed in central collisions

• Models of Zhao et al. and Liu et al.: direct J/ψ production with color screening + recombination

Zhao et al.: + J/ψ formation time effect and B-meson feed-down

→ Both models (*Zhao et al., Liu et al.*) describe the data well at low p_T

$J/\psi R_{AA}$ in Au+Au 200 GeV

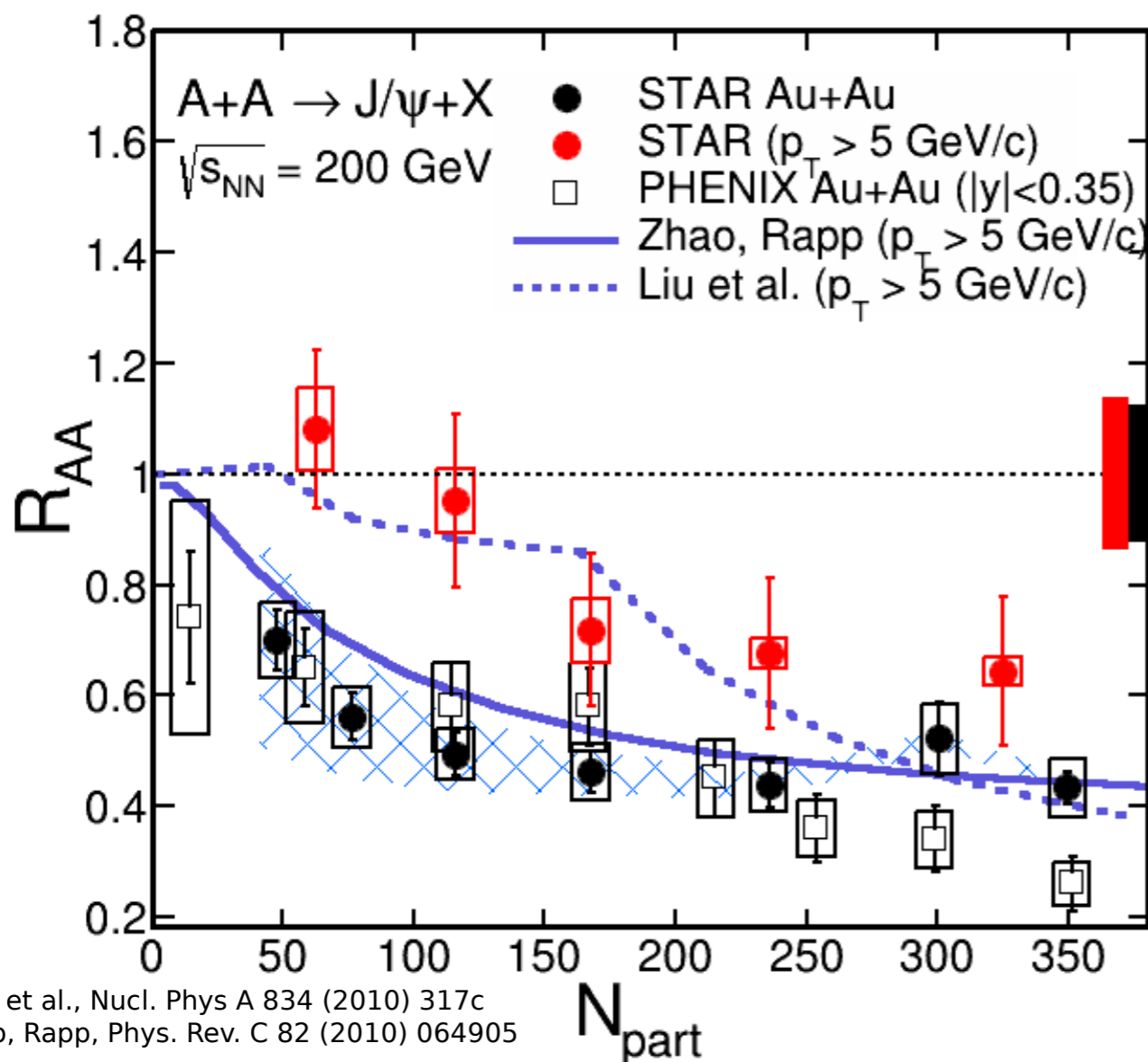

- ✓ Suppression increases with collision centrality
- ✓ High- p_T R_{AA} is systematically higher
- High- p_T J/ψ suppressed in central collisions

• Models of Zhao et al. and Liu et al.: direct J/ψ production with color screening + recombination

Zhao et al.: + J/ψ formation time effect and B-meson feed-down

- At high p_T Liu et al. model describes the data well, while Zhao et al. model underpredicts the R_{AA}

Y.Liu et al., Nucl. Phys A 834 (2010) 317c
 Zhao, Rapp, Phys. Rev. C 82 (2010) 064905

STAR high- p_T : Phys. Lett. B 722 (2013) 55
 STAR low- p_T : Phys. Rev. C 90 (2014) 24906

Energy dependence of J/ψ R_{AA}

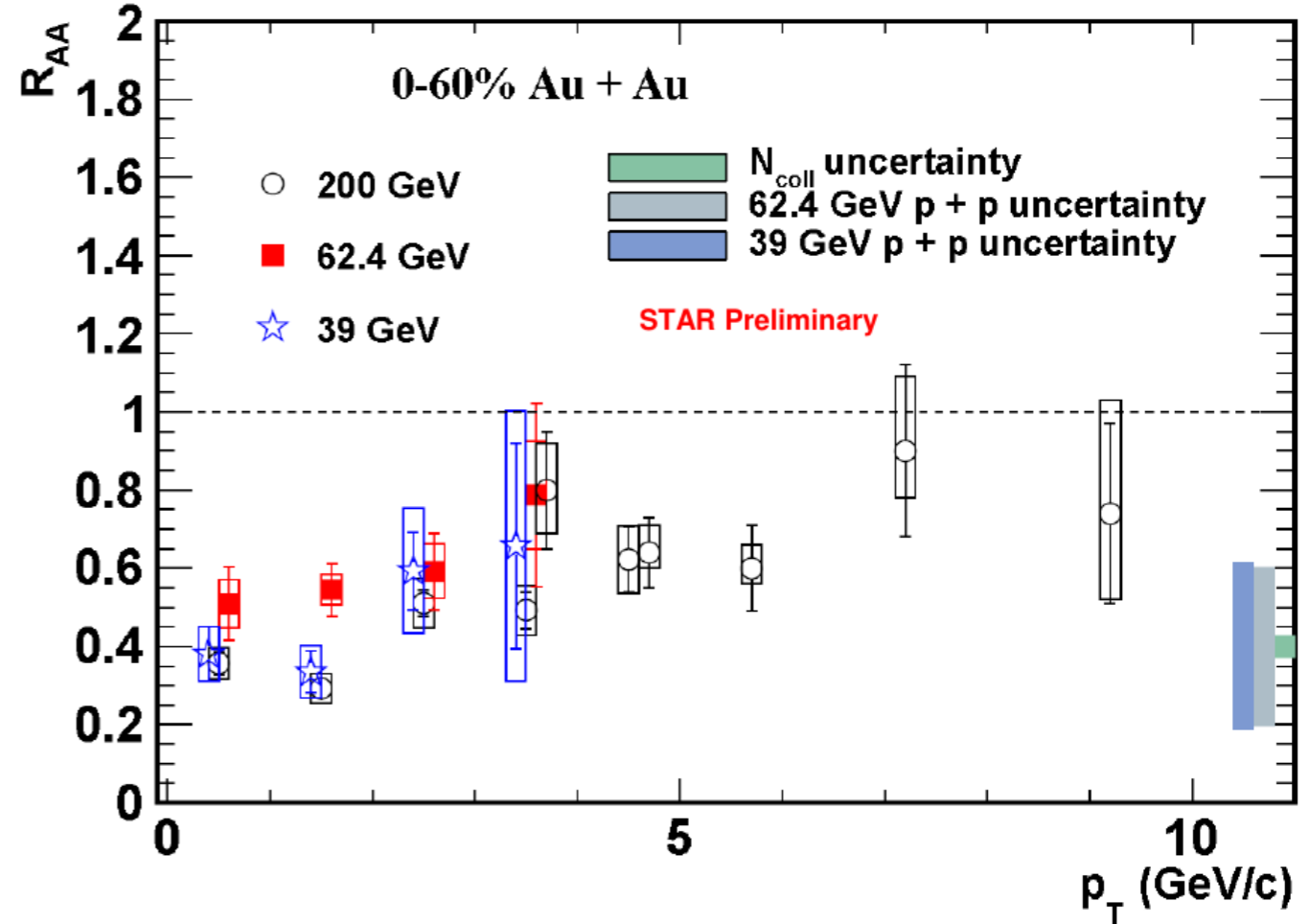
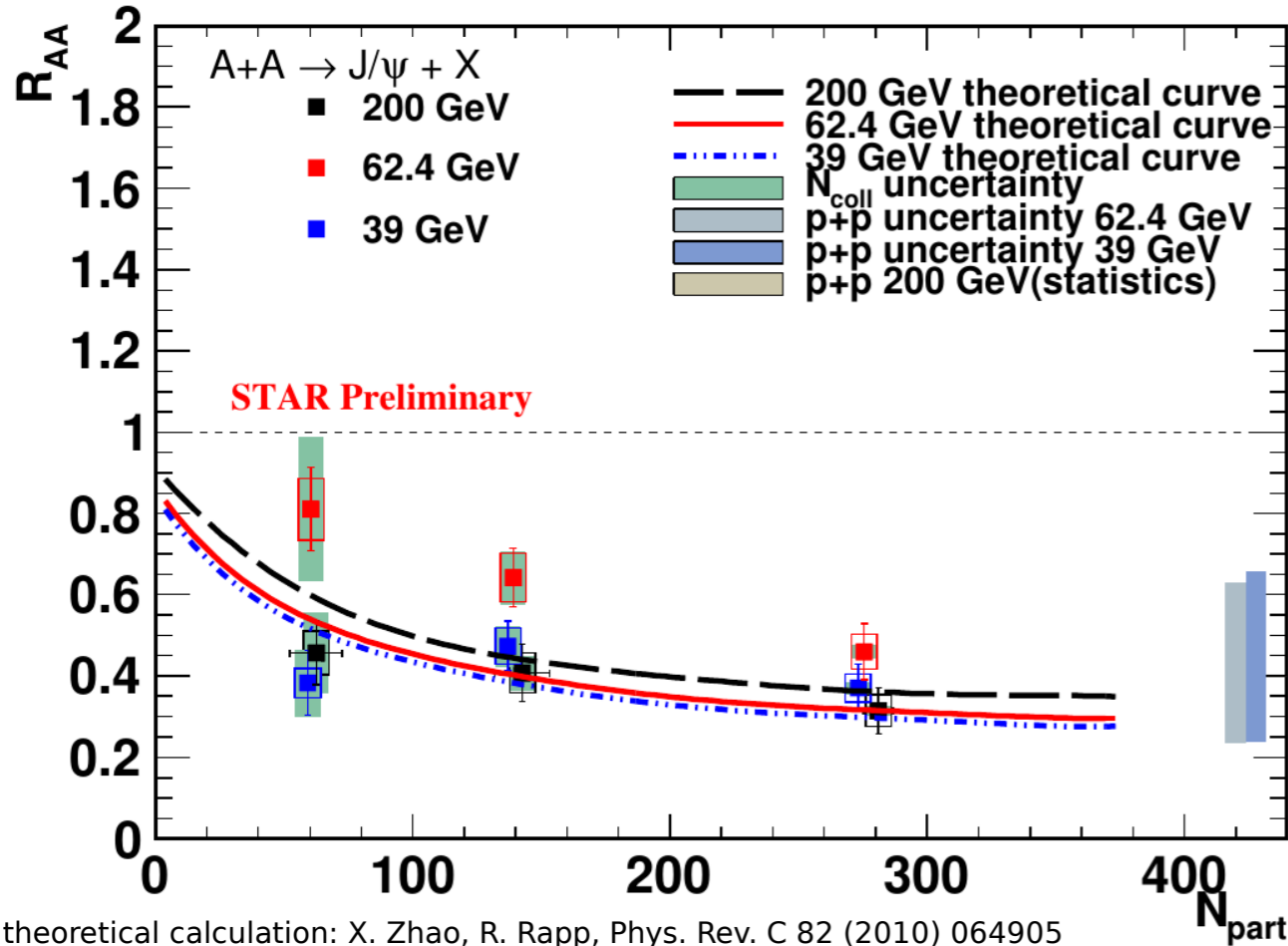

theoretical calculation: X. Zhao, R. Rapp, Phys. Rev. C 82 (2010) 064905
 CEM: R. E. Nelson, R. Vogt and A. D. Frawley, Phys. Rev. C 87, 014908 (2013).

- ✓ Suppression observed for all energies: 200, 62.4 and 39 GeV, similar trend in p_T
- No strong energy dependence of J/ψ R_{AA} within uncertainties
- Data agrees with the prediction of the two-component model
 - *p+p reference for 62.4 and 39 GeV data from Color Evaporation Model (CEM) - large theoretical uncertainties*

J/ψ in $U+U$ 193 GeV



- Higher energy density can be reached in $U+U$ collisions, at the same centrality

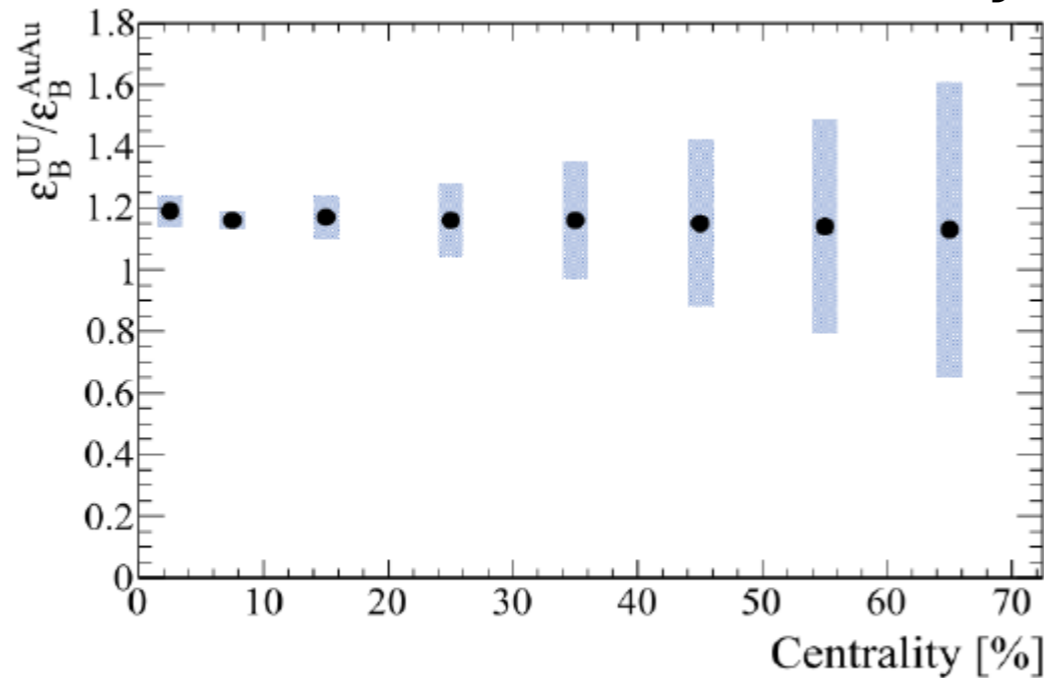

Kikola, Odyniec, Vogt, Phys. Rev. C 84, 054907

Au+Au Collisions



Oblate

U+U Collisions

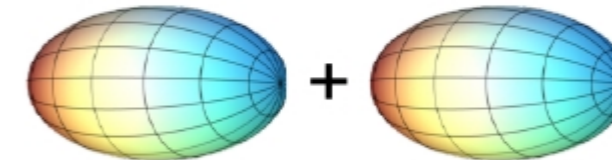

Prolate

- Higher N_{part}

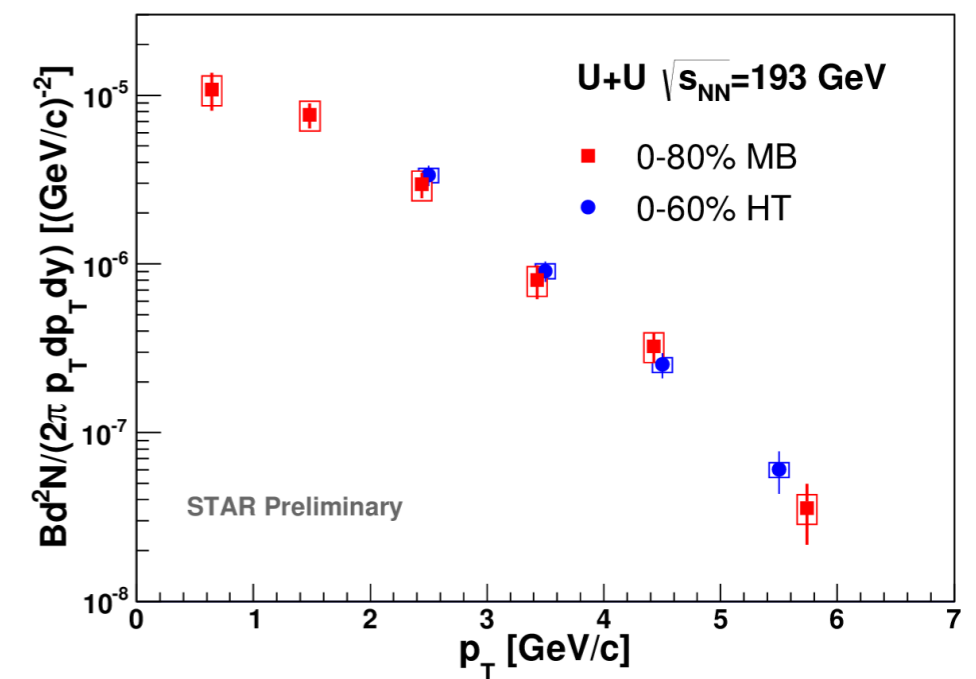
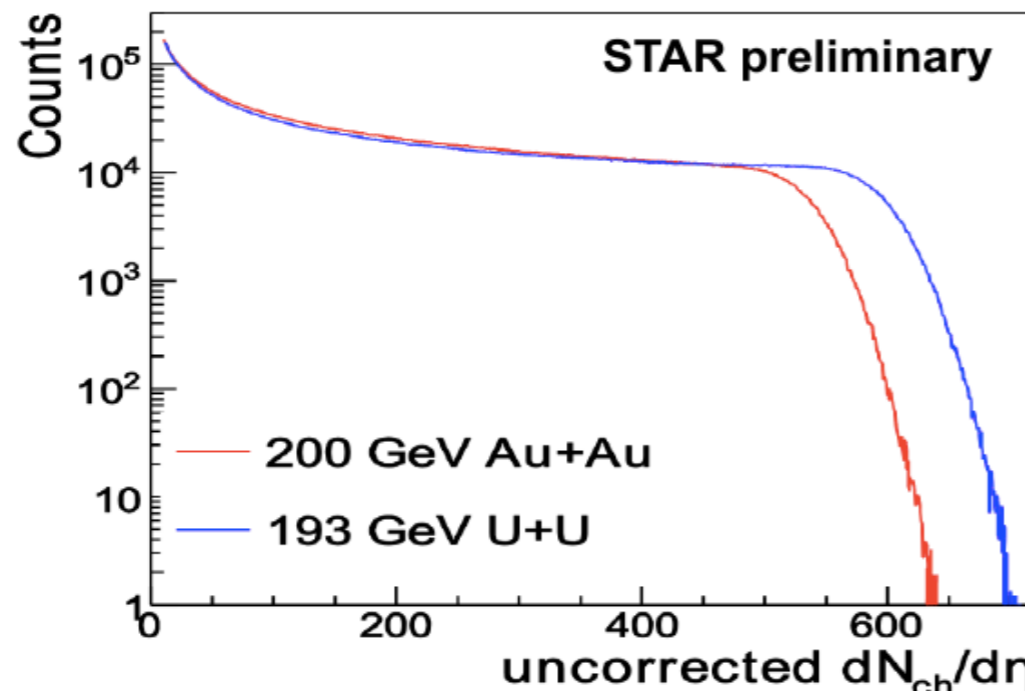

J/ψ in $U+U$ 193 GeV

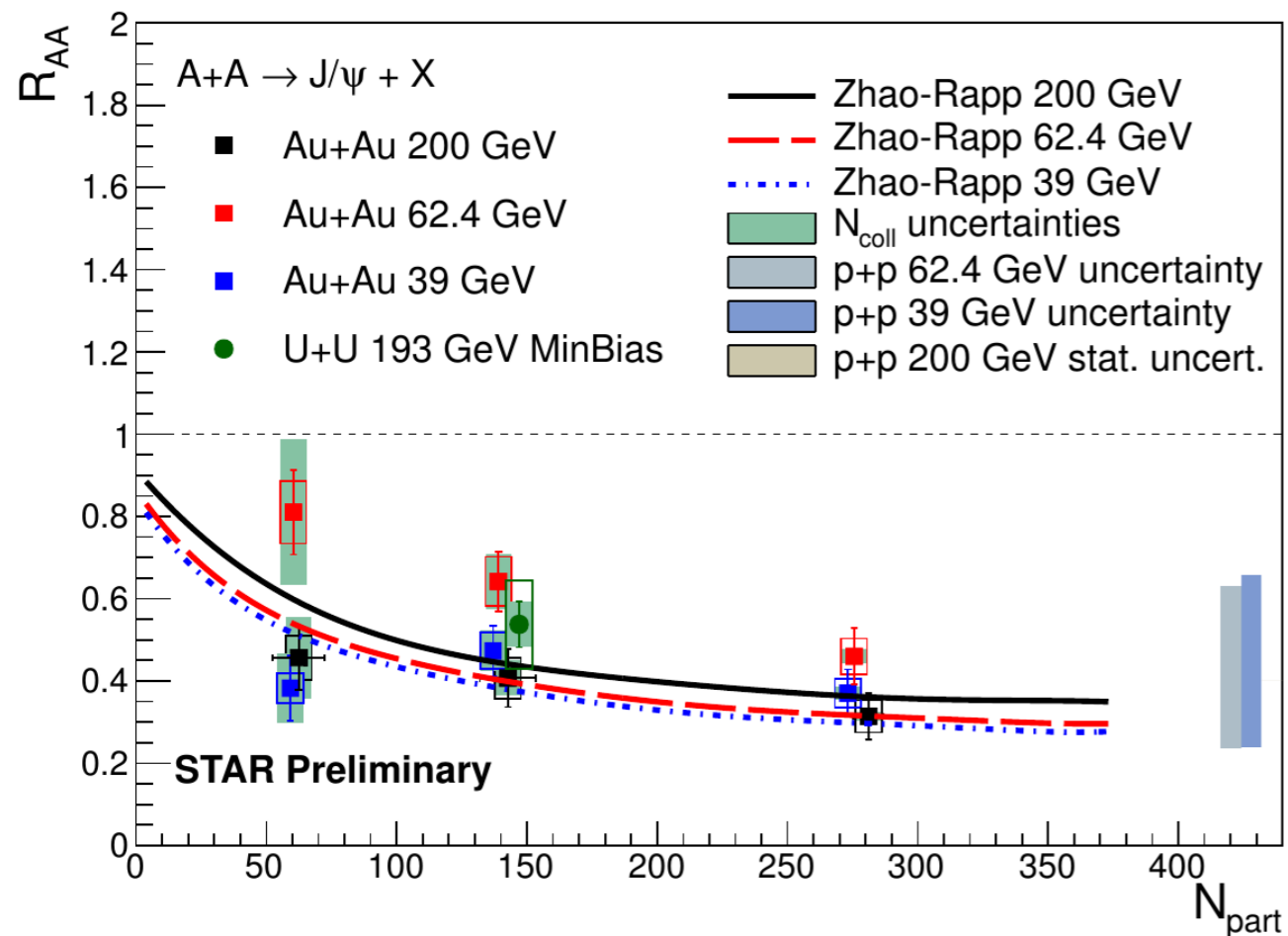

✓ Similar suppression pattern in $U+U$ and $Au+Au$ collisions, similar p_T trend

($p+p$ reference from 200 GeV)

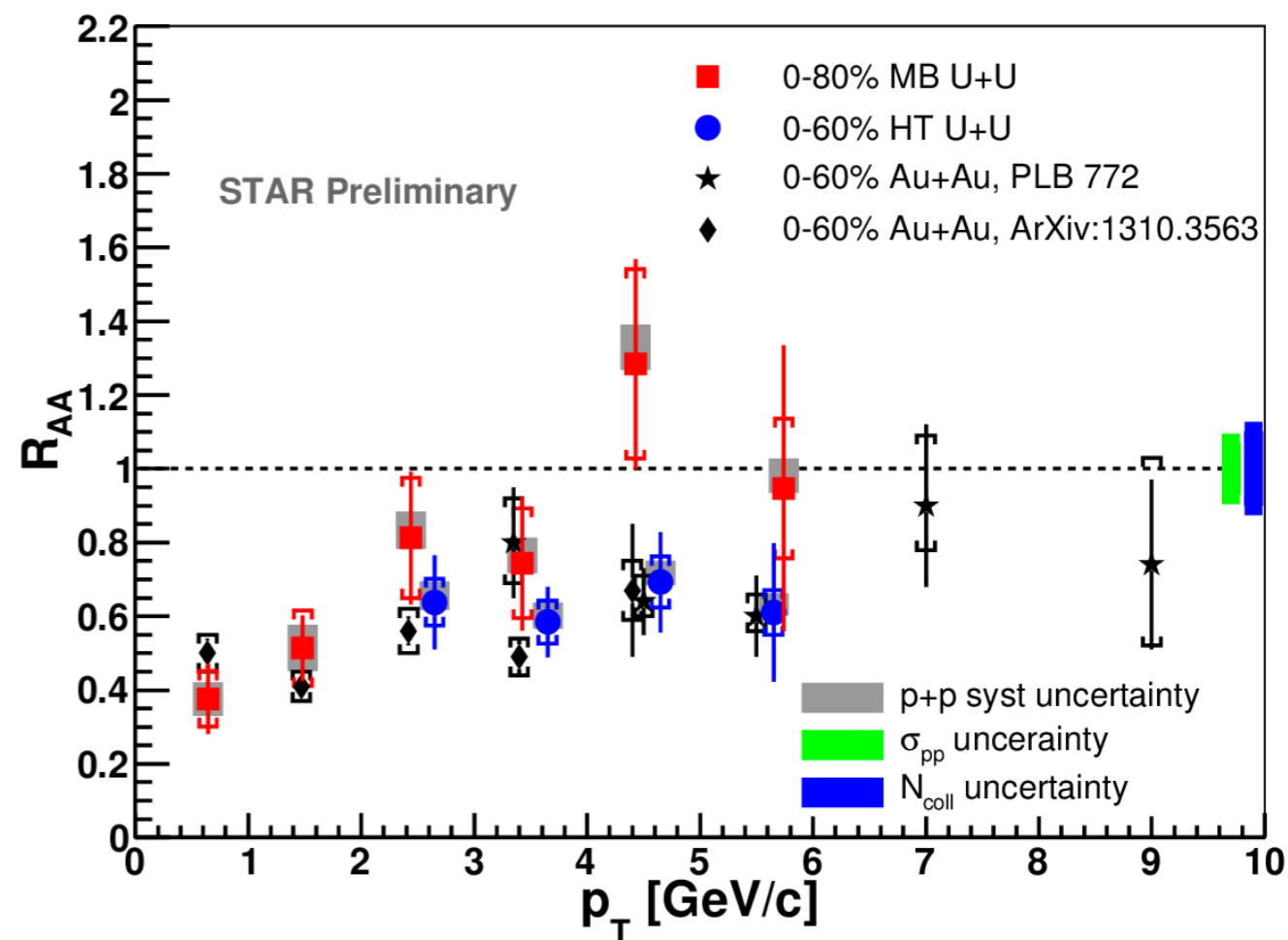

Υ in $d+Au$ 200 GeV, CNM effects

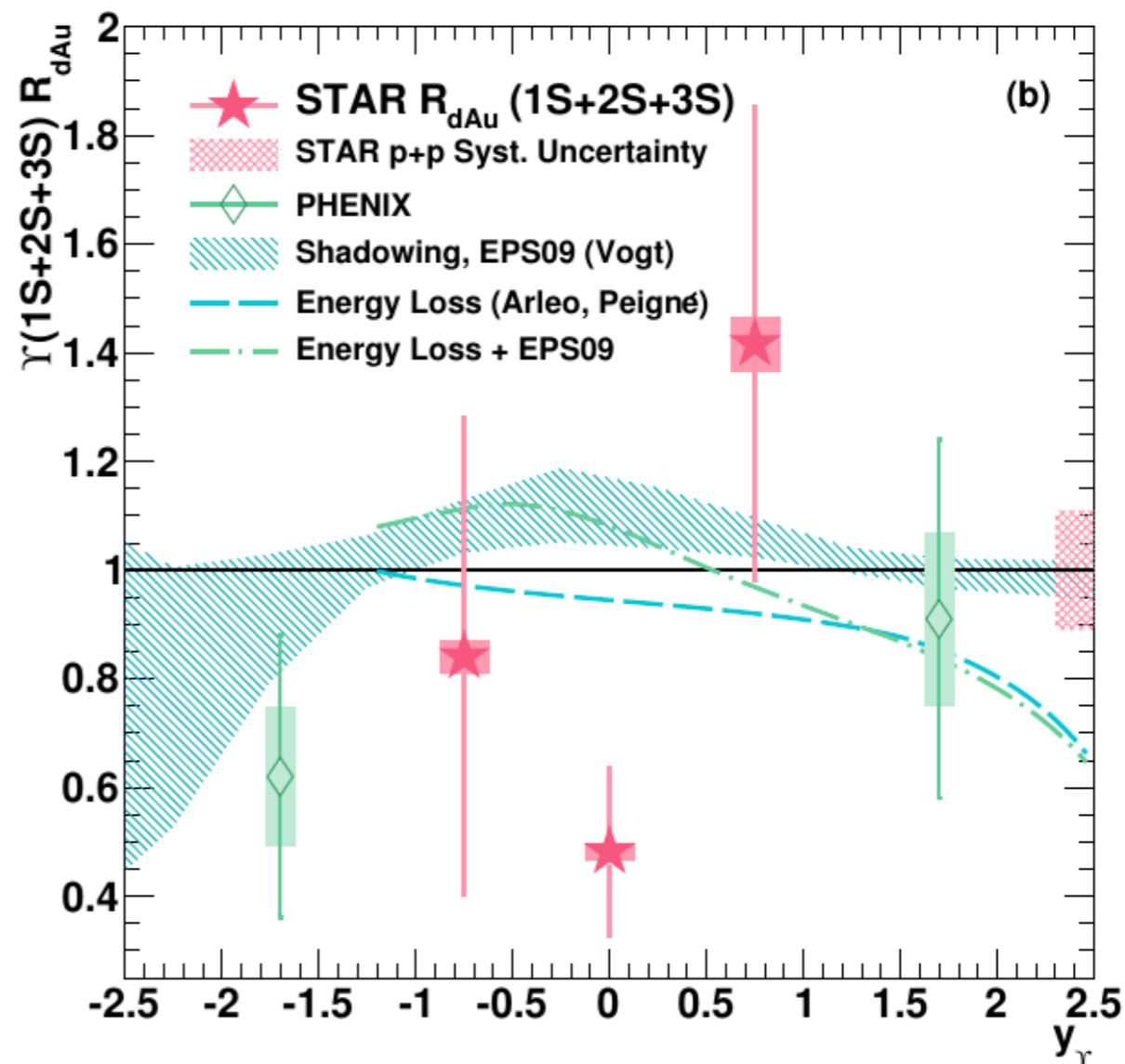
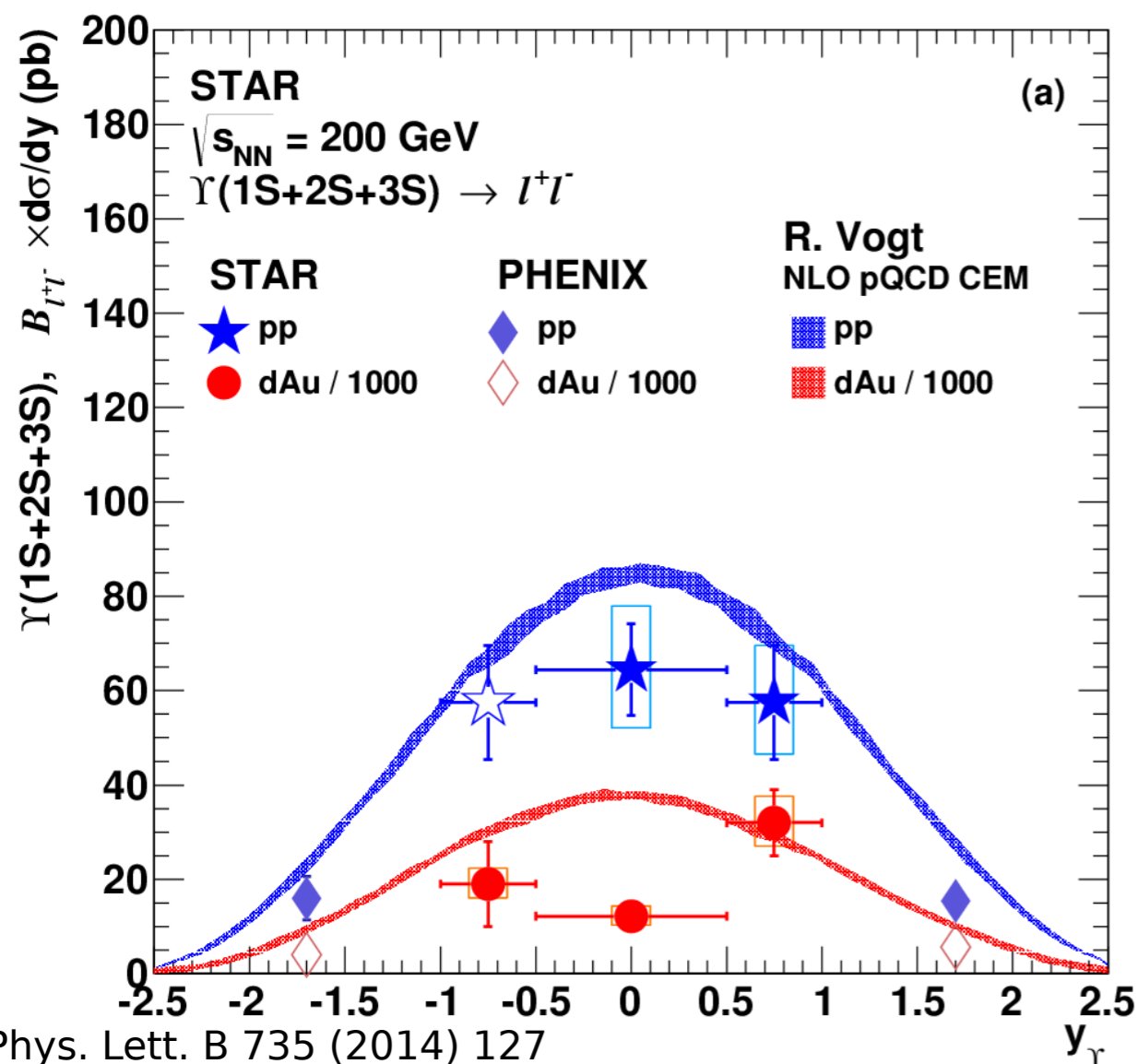

- ✓ Agreement with models except $y \sim 0$
- **Suppression at $y \sim 0$** , in addition to shadowing and initial state parton energy loss

(Υ - predicted negligible co-mover absorption and recombination)

ΥR_{AA} in Au+Au 200 GeV

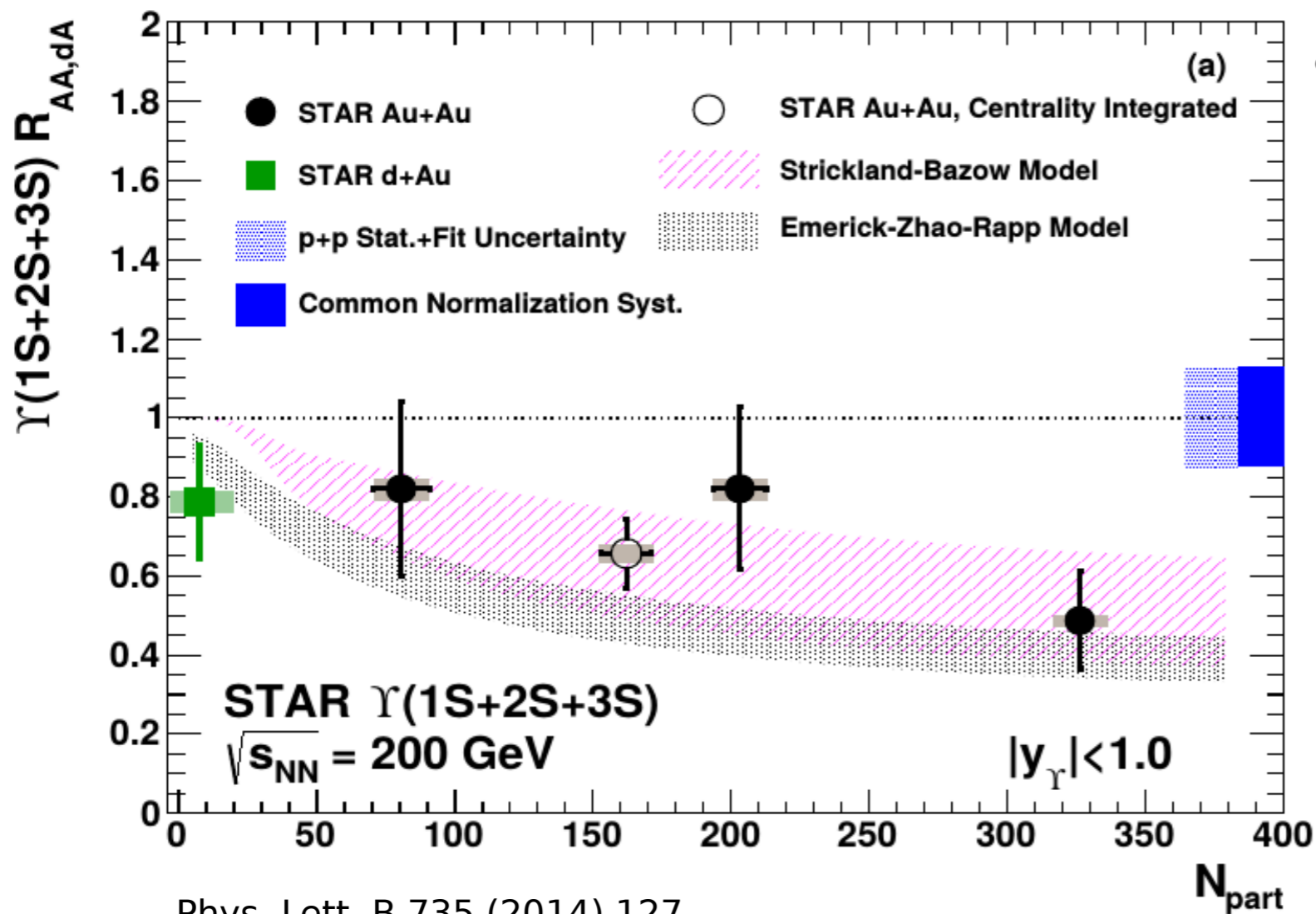

- *Strickland-Bazow Model* (*Nucl. Phys. A879, 25 (2012)*):
 $428 < T < 442$ MeV,
 internal energy potential
- *Emerick-Zhao-Rapp Model* (*Eur. Phys. J A48, 72 (2012)*):
 CNM effects included,
 strong binding scenario

- ✓ Suppression increases with collision centrality
- ✓ Strong suppression in central collisions
- Agreement with models that include presence of QGP

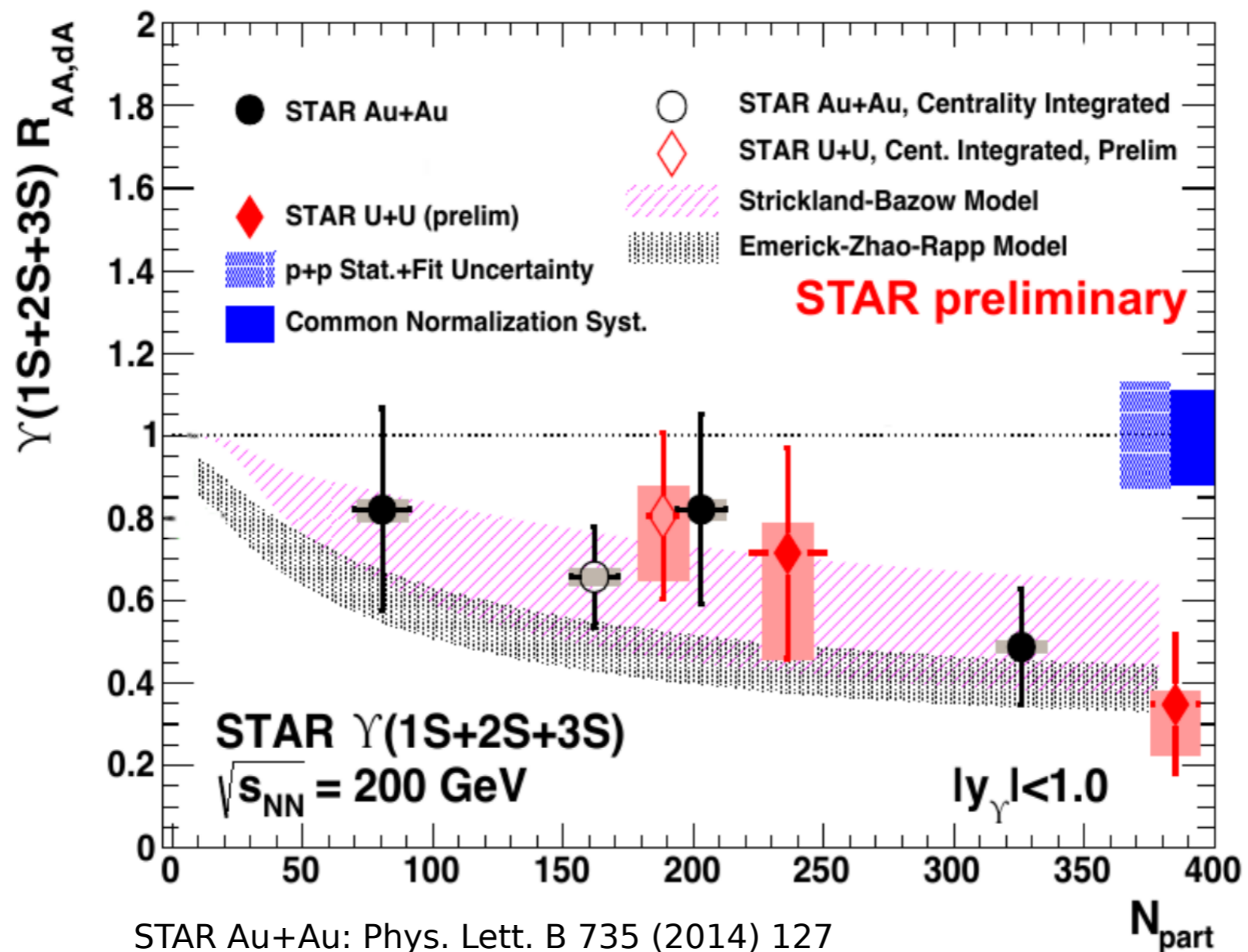

✓ The same trend in Au+Au and U+U collisions

Suppression of Υ states in Au+Au

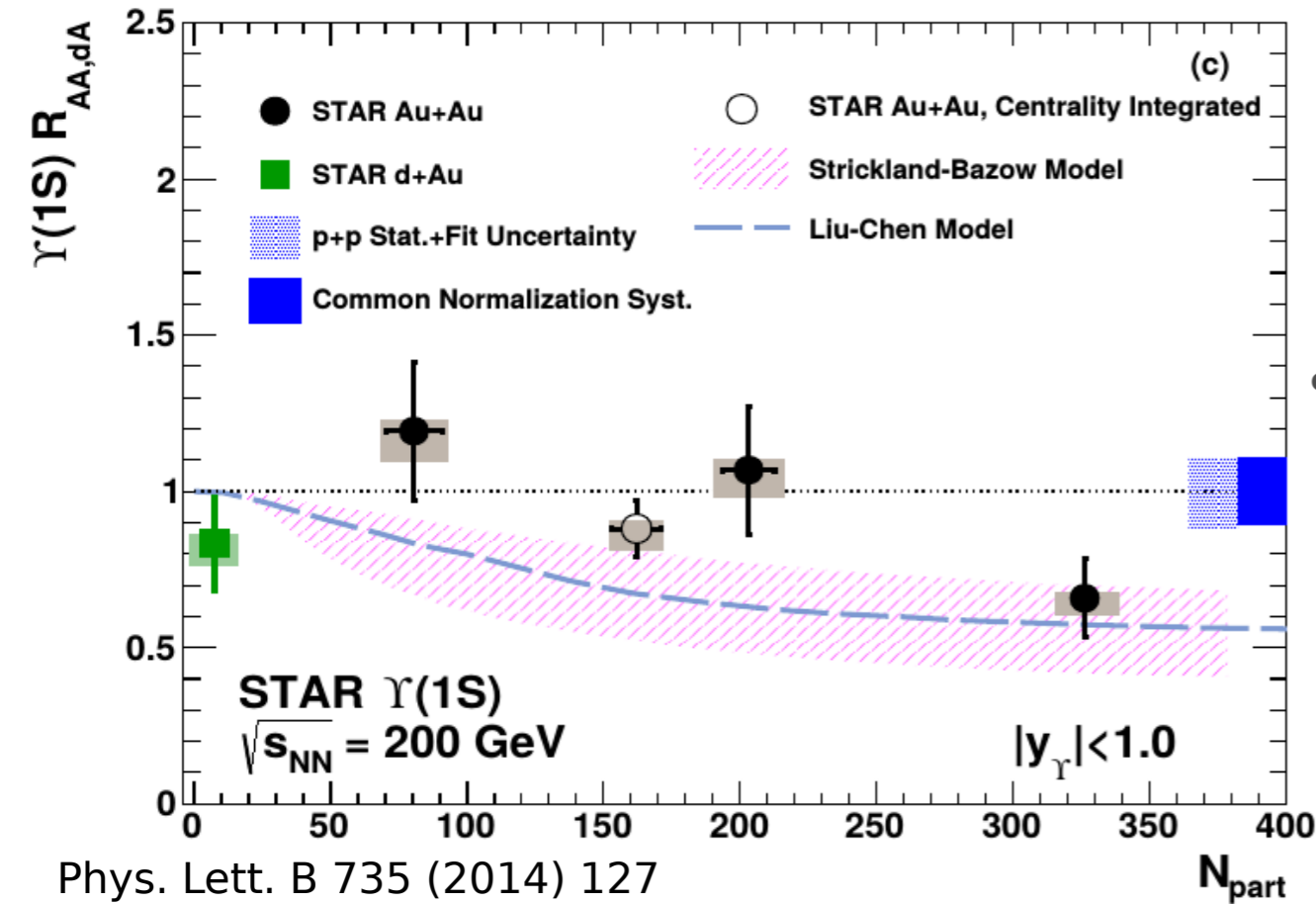

Phys. Lett. B 735 (2014) 127
 S-B Model: Nucl. Phys. A879, 25 (2012)
 Liu-Chen Model: Phys. Lett. B697 (2011) 32

- ✓ Suppression of $\Upsilon(1S)$ in central collisions consistent with model predictions
- Liu et al. Model - suppression mostly due to dissociation of the excited states (CNM effects not included)

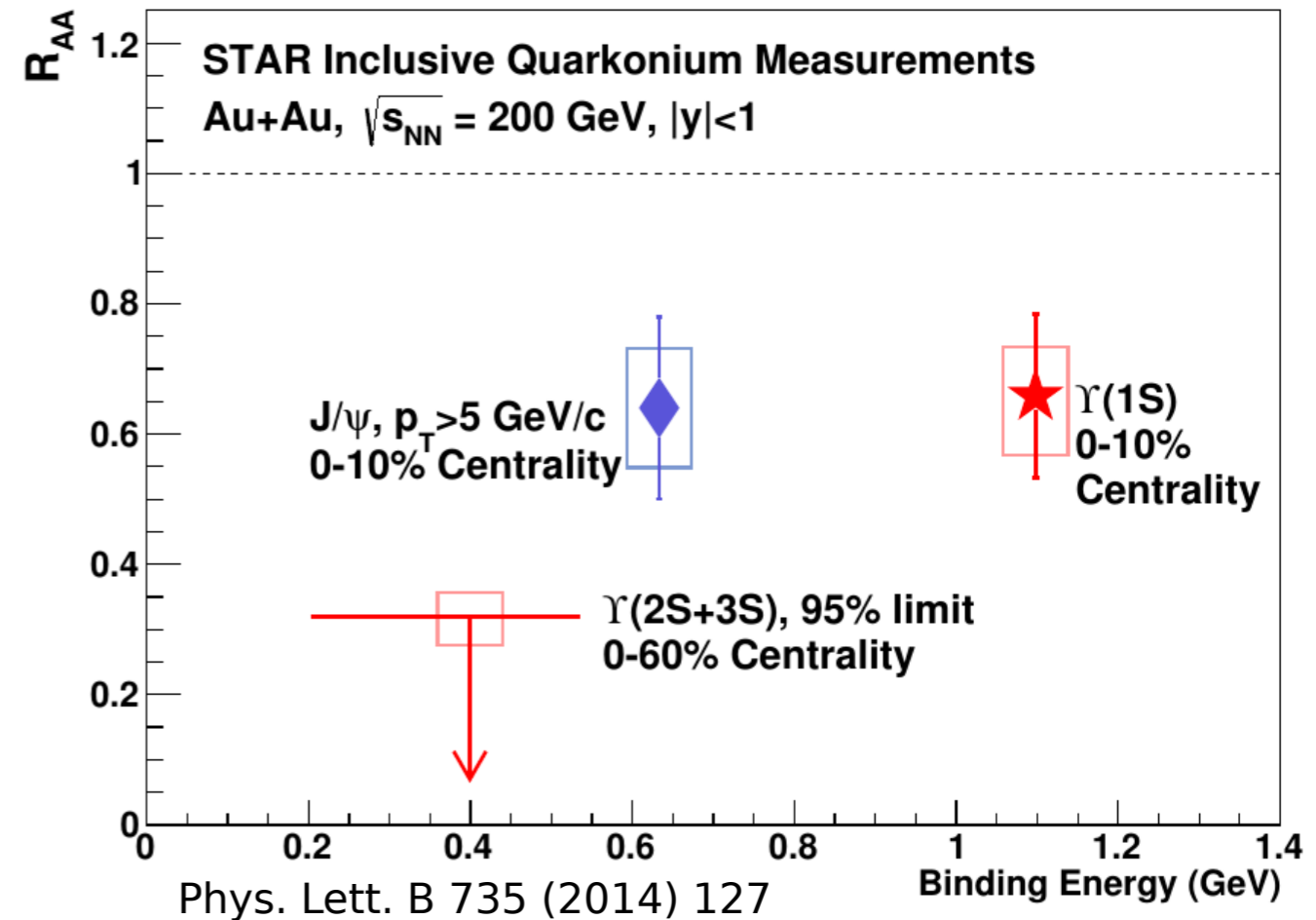

➤ Central collisions

- ✓ Indication of complete $\Upsilon(2S+3S)$ suppression
- ✓ Suppression of $\Upsilon(1S)$ similar to high- p_T J/ψ

Upgrades

Fully installed and take data since 2014

STAR



Muon Telescope Detector (MTD)

Precision quarkonium measurements via di- μ channel

μ advantages over e :

- No γ conversion
- Much less Dalitz decay contribution
- Less affected by radiative energy losses in the detector material

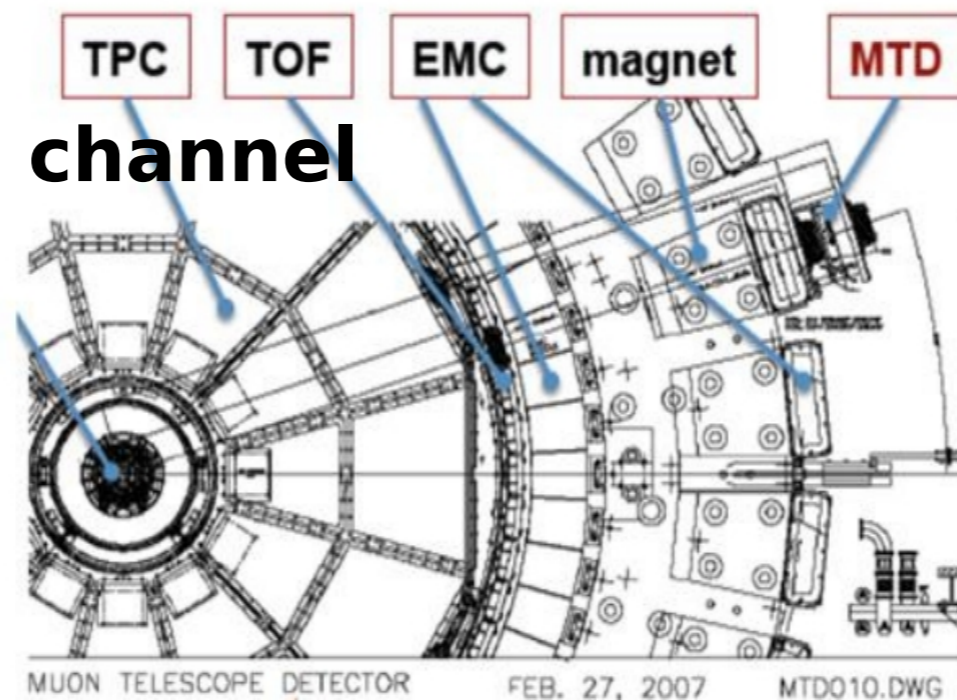

- × Acceptance: 45% at $|\eta| < 0.5$
- × Multi-gap Resistive Plate Chamber (MRPC) - gas detector
- × Long-MRPCs

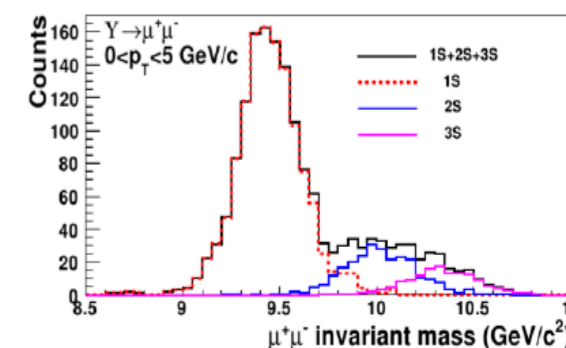

Heavy Flavor Tracker (HFT)

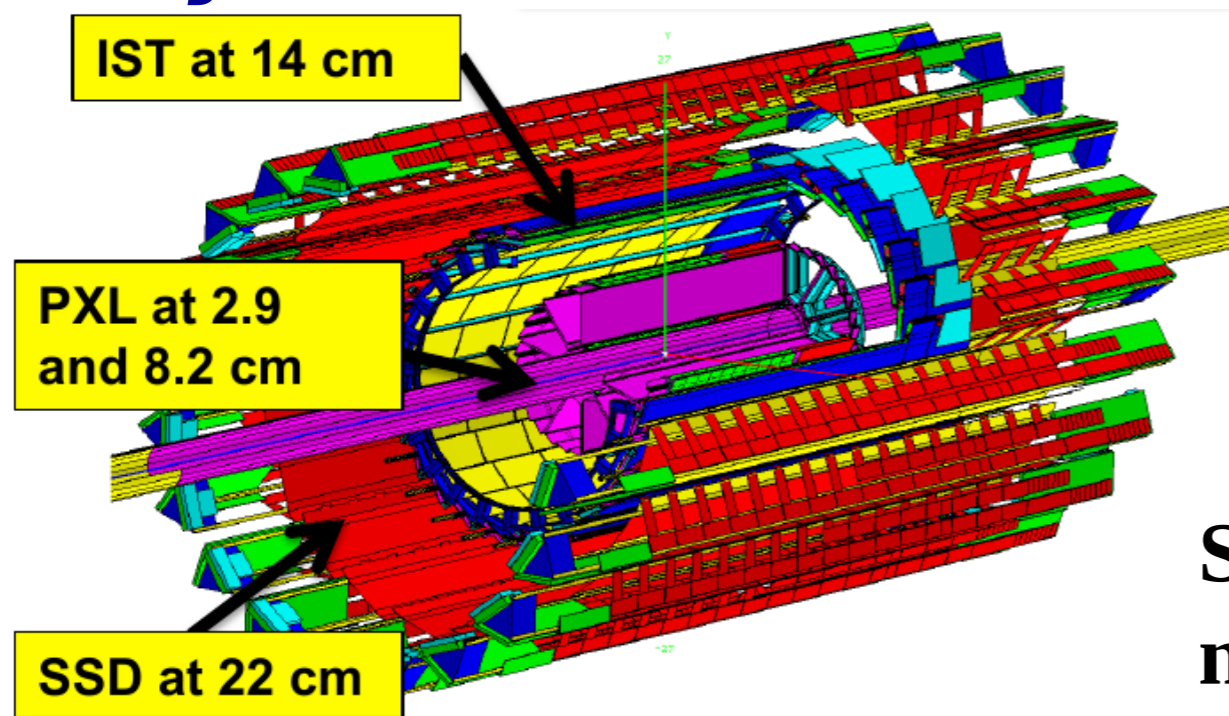

Inner tracking system with 3 sub-systems

Precise pointing resolution

$$B \rightarrow J/\psi + X$$

Separate prompt J/ψ production from non-prompt one, from B decays

- No strong energy dependence of J/ψ suppression in Au+Au 200, 62.4, 39 GeV
- Similar J/ψ and Υ suppression in Au+Au and U+U
- Υ and high- p_T J/ψ suppressed in central Au+Au 200 GeV
- Indication for complete $\Upsilon(2S)$ and $\Upsilon(3S)$ suppression in central collisions
 - ➔ Signals of the QGP presence
- *HFT and MTD since 2014 – significant improvement of quarkonium measurements*

This work was supported by the European social fund within the framework of realizing the project „Support of inter-sectoral mobility and quality enhancement of research teams at Czech Technical University in Prague“, CZ.1.07/2.3.00/30.0034.

Thank you !

J/ψ

- $p+p$, $\sqrt{s} = 500 \text{ GeV}$, and $\psi(2S)$
- $Au+Au$, $\sqrt{s_{NN}} = 200, 62.4, 39 \text{ GeV}$
- $U+U$, $\sqrt{s_{NN}} = 193 \text{ GeV}$

$Upsilon$

- $p+p$, $\sqrt{s} = 200 \text{ GeV}$
- $d+Au$, $\sqrt{s_{NN}} = 200 \text{ GeV}$
- $Au+Au$, $\sqrt{s_{NN}} = 200 \text{ GeV}$
- $U+U$, $\sqrt{s_{NN}} = 193 \text{ GeV}$
- $\Upsilon(1S)$ at $\sqrt{s_{NN}} = 200 \text{ GeV}$

J/ψ polarization in $p+p$ 200 GeV

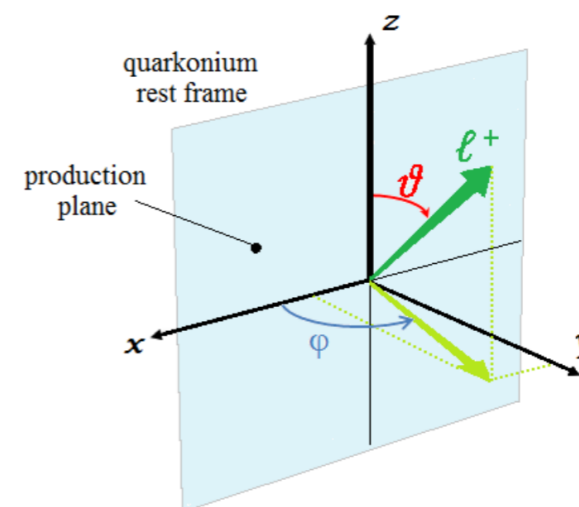
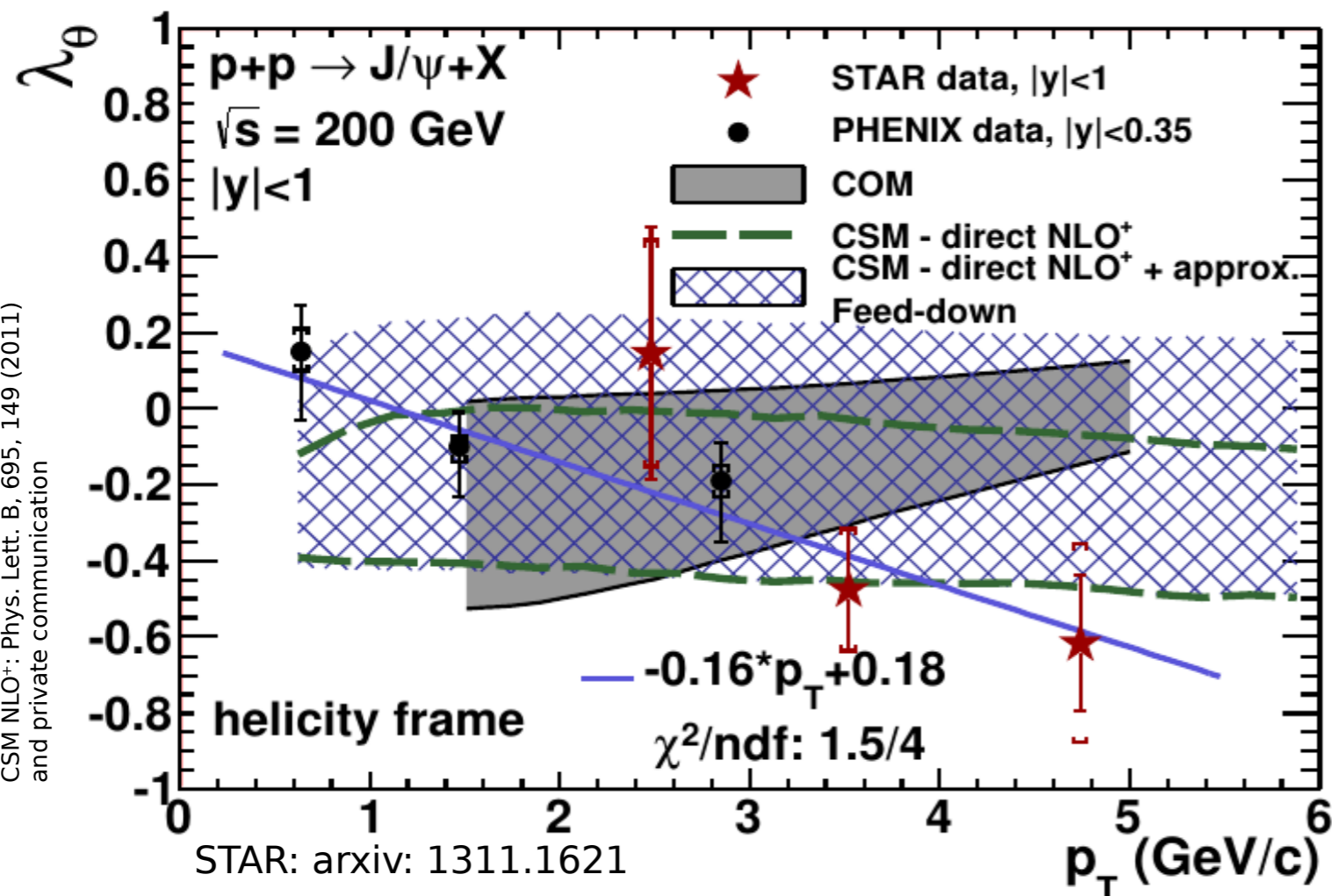

The angular distribution integrated over the azimuthal angle:

$$W(\cos\theta) \propto 1 + \lambda_\theta \cos^2\theta$$

λ_θ – polarization parameter

$\lambda_\theta = -1$ - longitudinal polarization

$\lambda_\theta = 1$ - transverse polarization

- ✓ Polarization parameter λ_θ is measured in the helicity frame at $|y| < 1$ and $2 < p_T < 6$ GeV/c
- RHIC data indicate trend towards longitudinal polarization with increasing p_T
- The result is consistent with NLO⁺ CSM

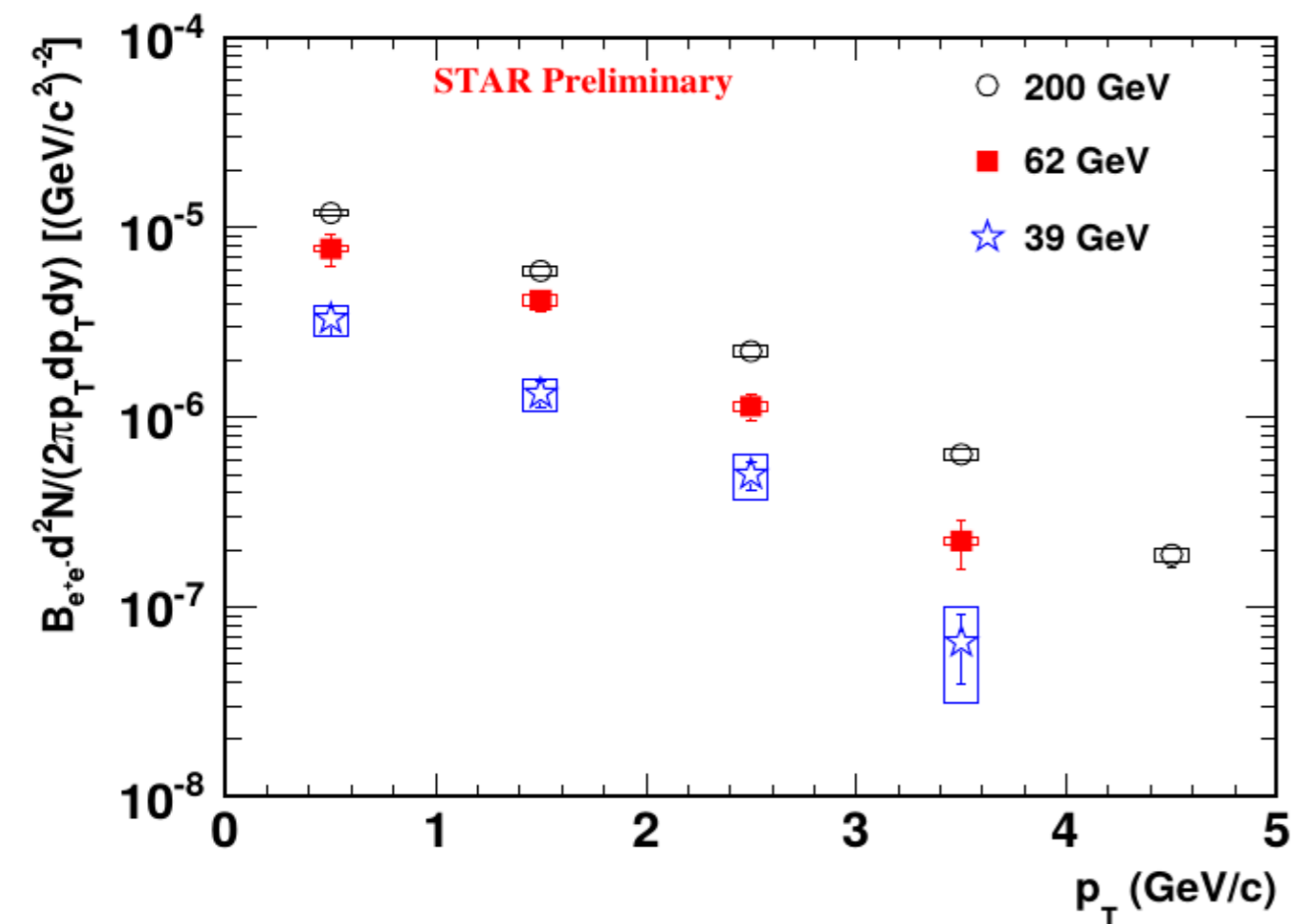

✓ Larger invariant yields at larger center-of-mass energy

- ✓ Similar R_{CP} in 62.4 and 200 GeV collisions
- ✓ Large uncertainties of 39 GeV result

• Reference: 40-60% centrality

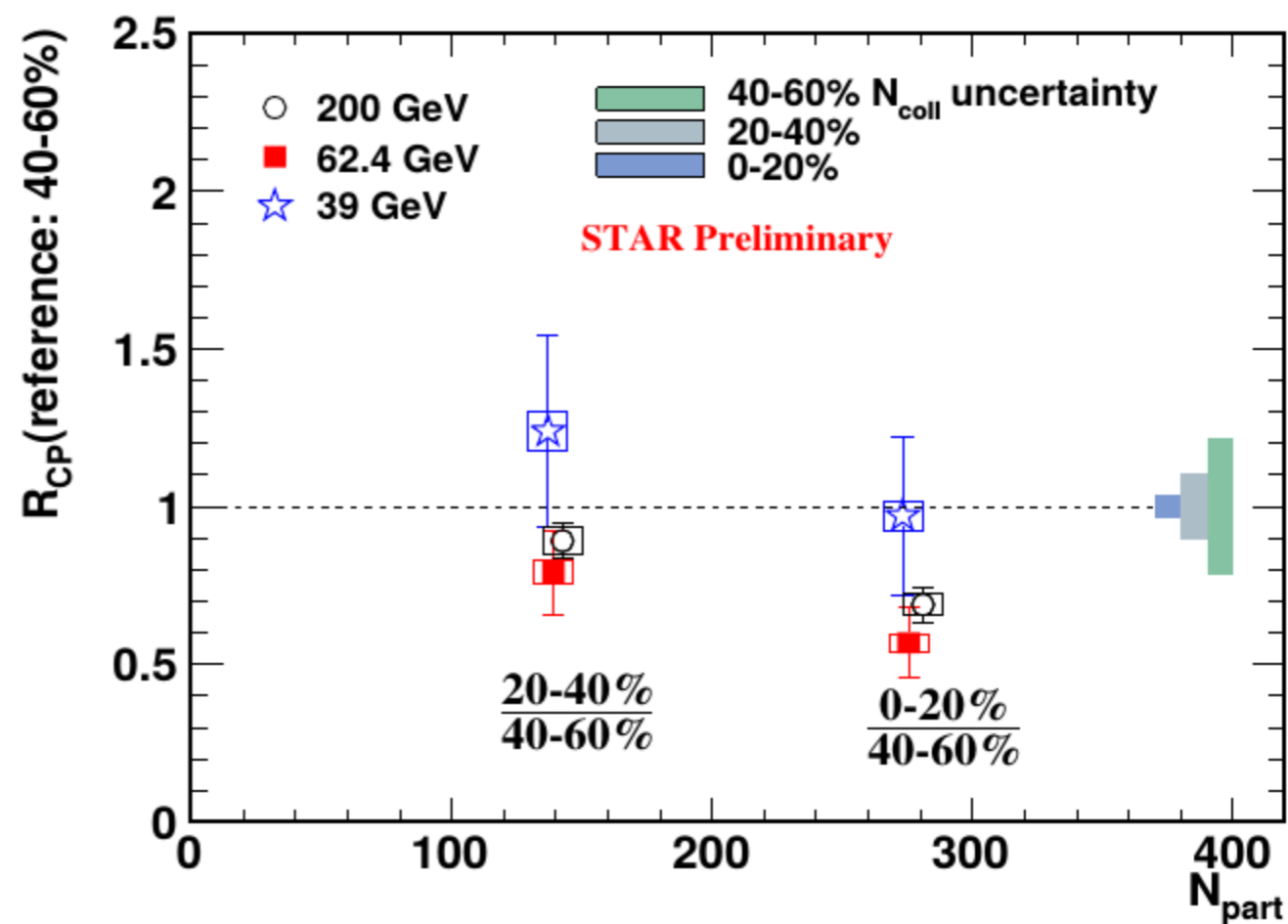

Upsilon in d+Au 200 GeV, CNM effects

STAR

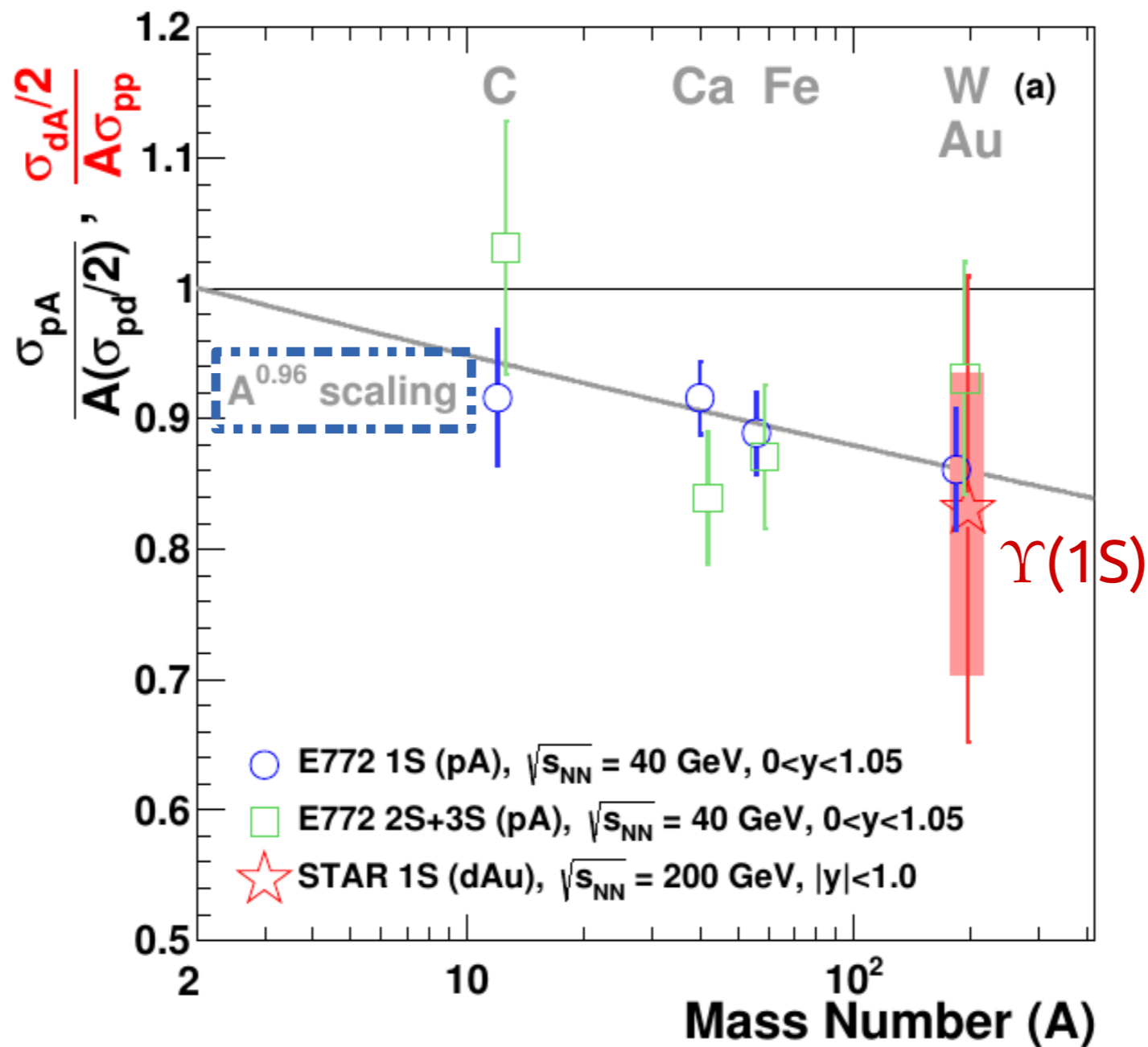

- ✓ Similar suppression seen at E772
 - *Better understanding of CNM effects needed*

Heavy Flavor Tracker (HFT)

STAR

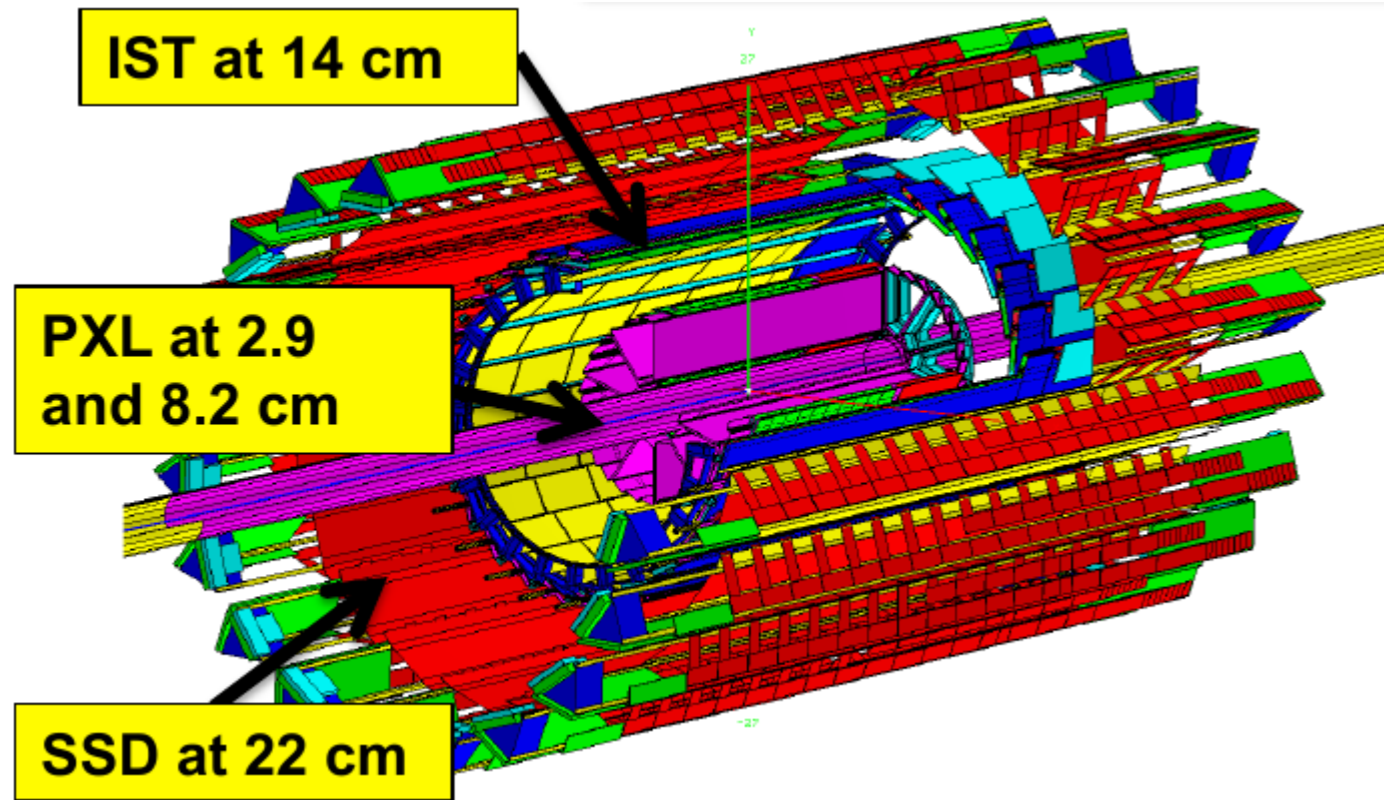

- Inner tracking system with 3 sub-systems
- Direct topological reconstruction of a decay vertex

Precise pointing resolution

$$B \rightarrow J/\psi + X$$

Separate prompt J/ψ production from non-prompt one, from B decays

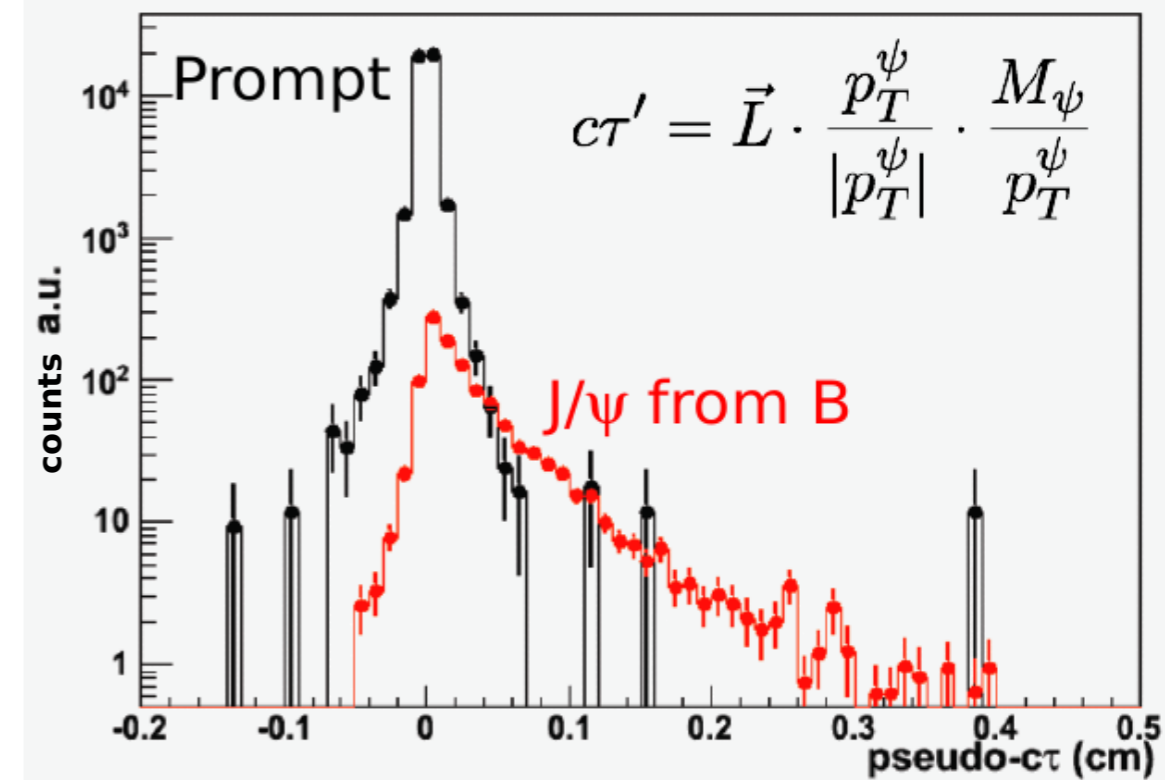

Fully installed and takes data since 2014

Muon Telescope Detector (MTD)



Precision quarkonium measurements via di- μ channel

μ advantages over e :

- No γ conversion
- Much less Dalitz decay contribution
- Less affected by radiative losses in the detector material

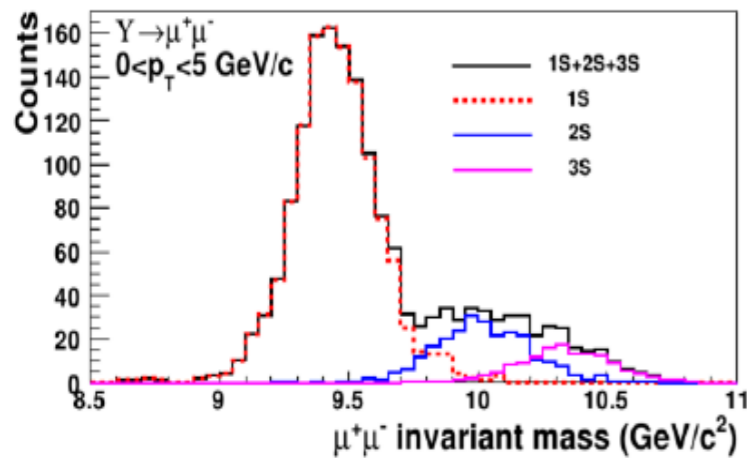

- Multi-gap Resistive Plate Chamber (MRPC) - gas detector
- Long-MRPCs

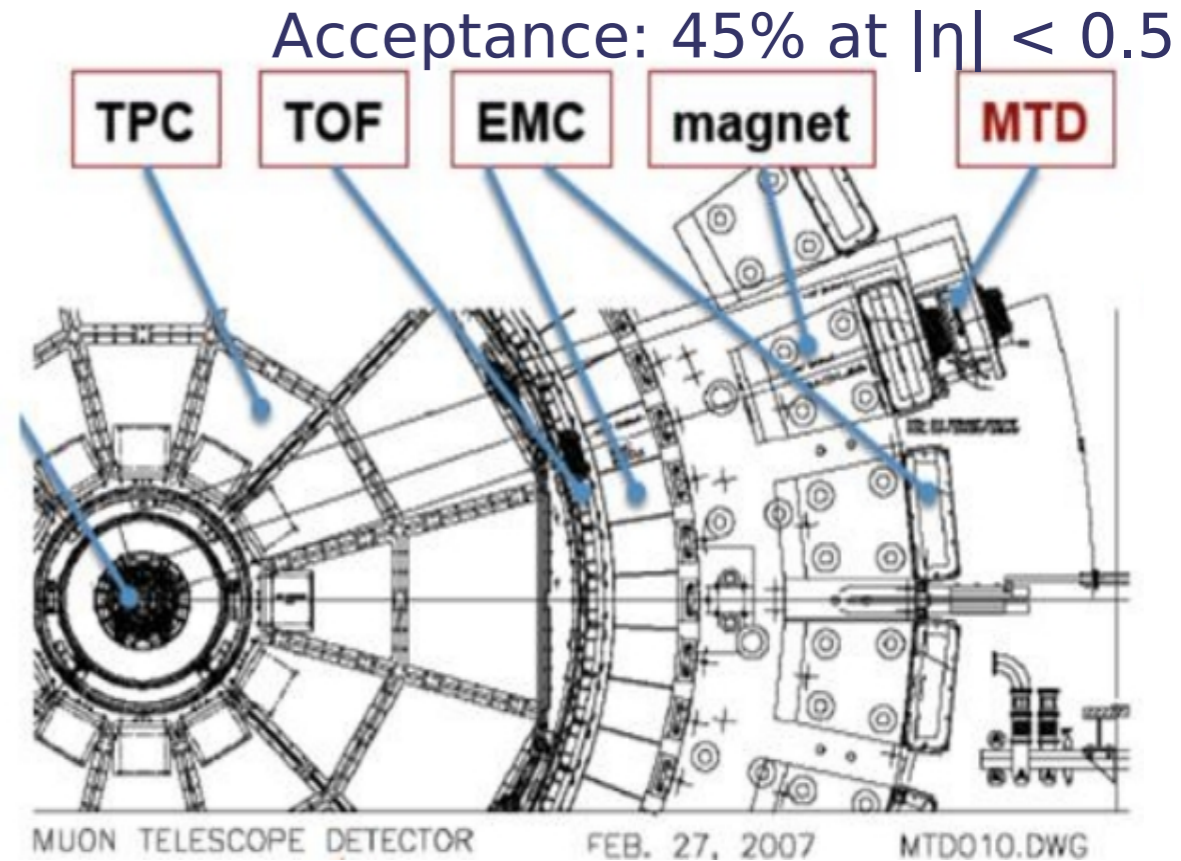

simulations

- Excellent mass resolution
- Trigger capability for low and high p_T J/ψ in central Au+Au

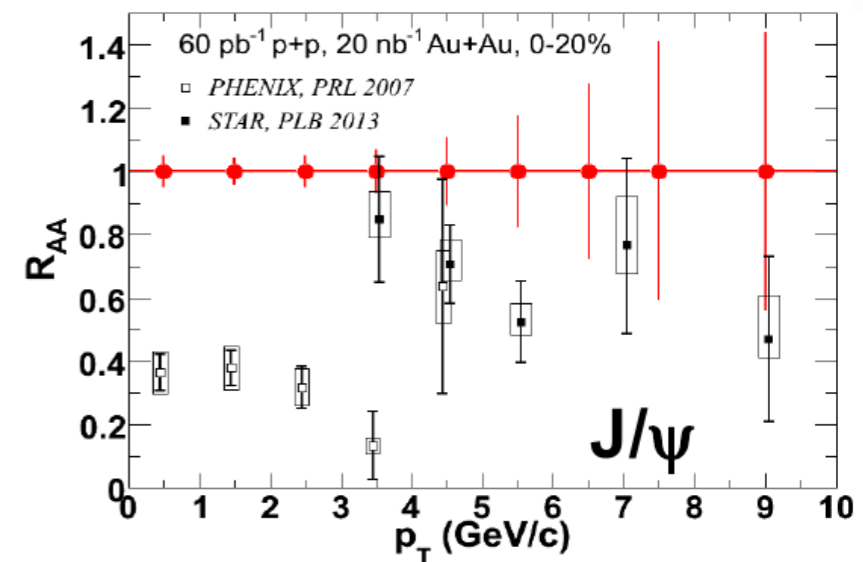
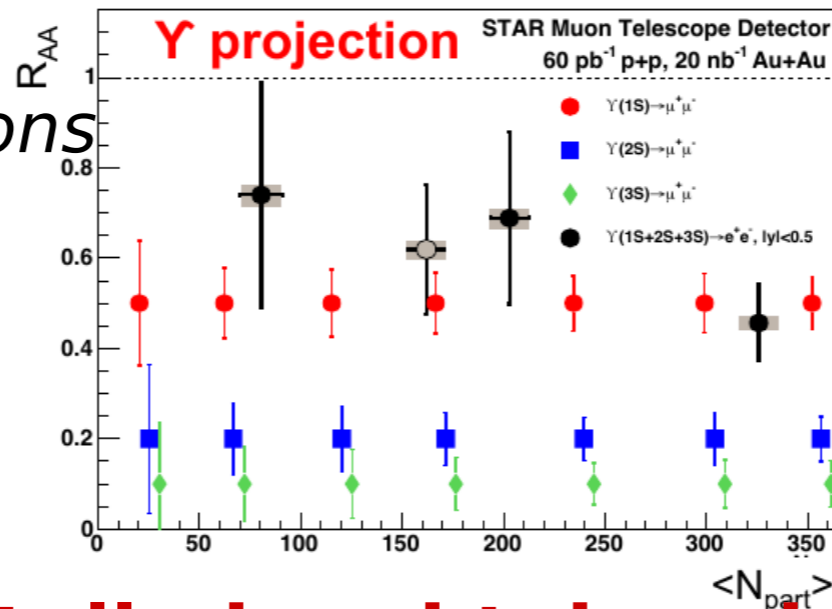

Fully installed and takes data since 2014