

# STAR Heavy Flavor Tracker

Qiu Hao (LBNL)  
for the STAR Collaboration

# Outline

- Physics motivation
- Design
  - Heavy Flavor Tracker
  - PiXeL detector
  - Monolithic Active Pixel Sensors
- Status and performance
  - Status
  - Signal, pedestal and noise scan
  - Efficiency
  - Survey and alignment
  - Hit residual and track DCA
- Summary

# Physics Motivation

- Heavy flavor
    - $m_{b,c} \gg T_C, \Lambda_{\text{QCD}}, m_{u,d,s}$
    - Produced early in initial hard scatterings
    - Total number conserved in system evolution at RHIC
- } Good probe to QGP
- However, it's also difficult to study heavy flavor quarks in experiments
    - Limited yield comparing with light flavor particles
    - Large combinatorial background for direct reconstruction of open heavy flavor hadrons without displaced decay vertex reconstruction
    - Large kinematics smearing for studies with electrons from semi-leptonic decay
  - A precision vertex detector will be an important tool to asses HF physics.

# How Heavy Flavor Tracker Helps

- HFT can be used to study heavy flavor production by reconstruction of displaced decay vertices
  - $D^0 \rightarrow K^- \pi^+$ 
    - BR = 3.83 %       $c\tau \sim 120 \mu\text{m}$
  - $\Lambda_c^+ \rightarrow p K^- \pi^+$ 
    - BR = 5.0 %       $c\tau \sim 60 \mu\text{m}$
  - B mesons  $\rightarrow J/\psi + X$  or  $e + X$ 
    - $c\tau \sim 500 \mu\text{m}$

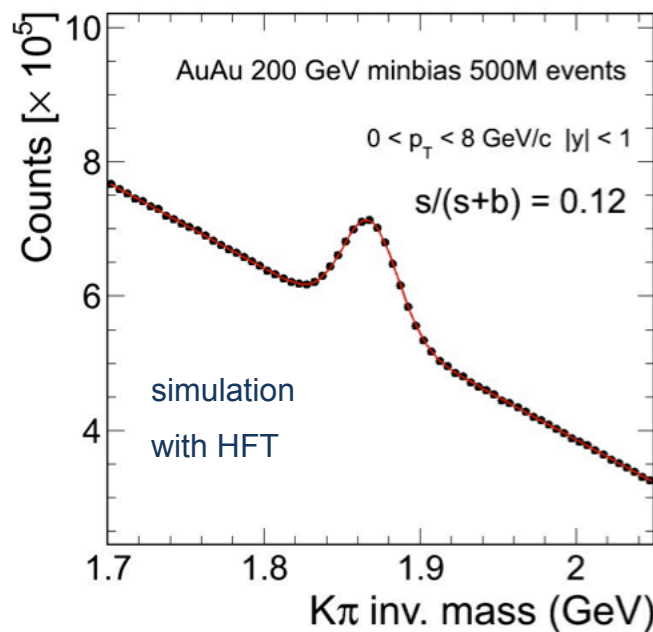
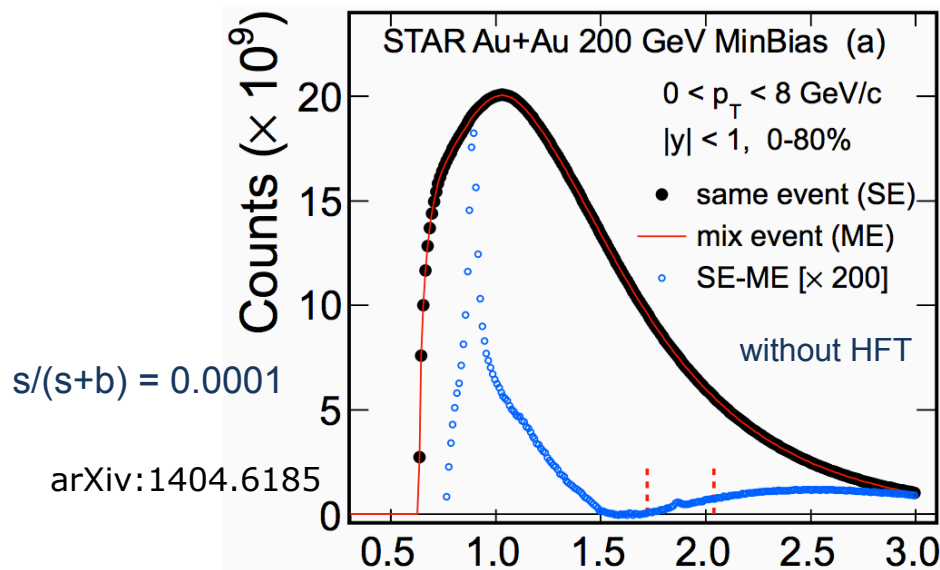
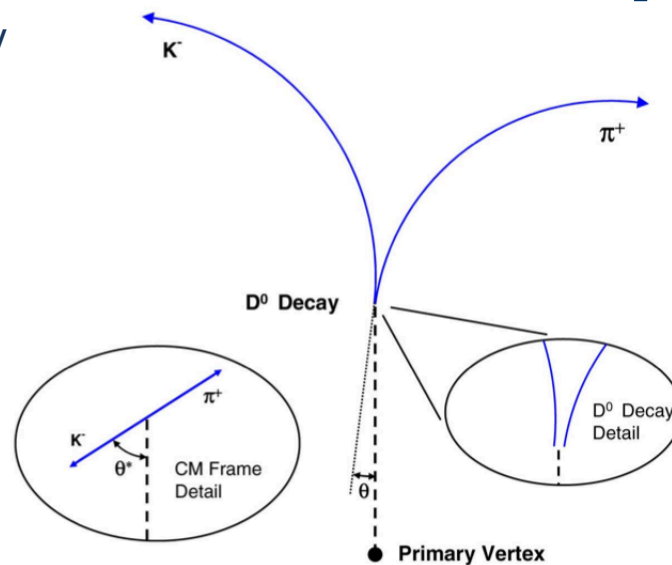

# Examples of Physics with HFT

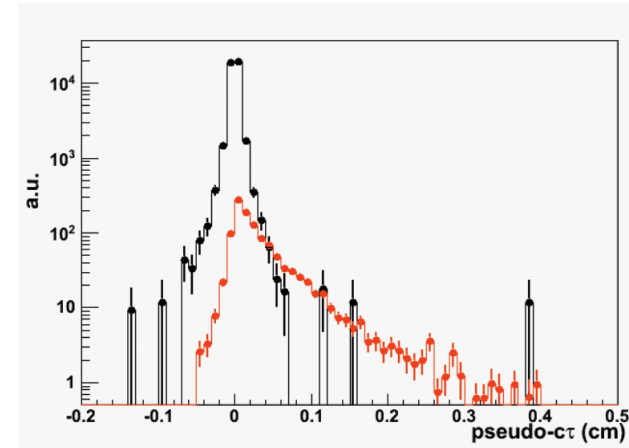
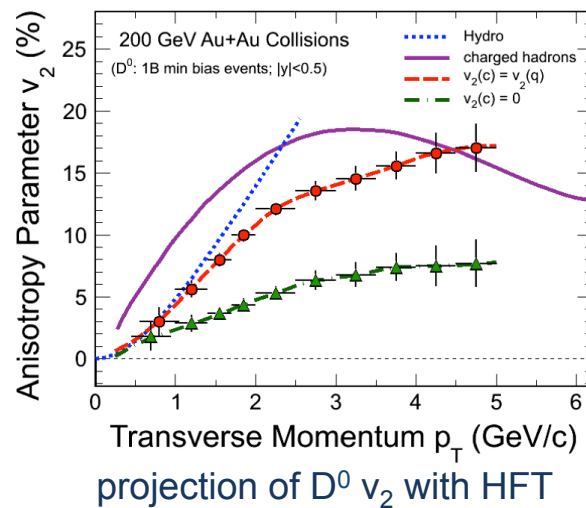
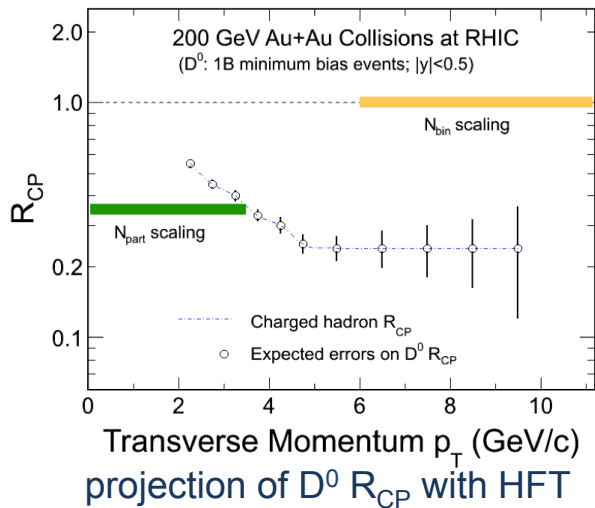

simulation of separating prompt  
and B decayed  $J/\psi$  with HFT

- Total charm yield  $\longrightarrow$  baseline for charmonium suppression & coalescence
- $R_{CP}$ ,  $R_{AA}$   $\longrightarrow$  energy loss mechanism, QCD in dense medium
- Charm collectivity  $\longrightarrow$  degree of light flavor thermalization
- Low radiation length enables reconstruction of  $D^0$  down to very low  $p_T$ , enabling more direct and precise measurement of total charm cross section and charm flow.
- Separating charm and beauty  $\longrightarrow$  probing the medium with heavy quarks with different mass

# HFT in STAR

**Tracking & dE/dx:  
Time Projection Chamber**

**Particle ID:  
Time Of Flight detector**

**Electromagnetic  
Calorimetry:  
Barrel EMC  
+Endcap EMC**

**Muon Telescope  
Detector (runs 13/14)**

**Heavy Flavor  
Tracker (run 14)**

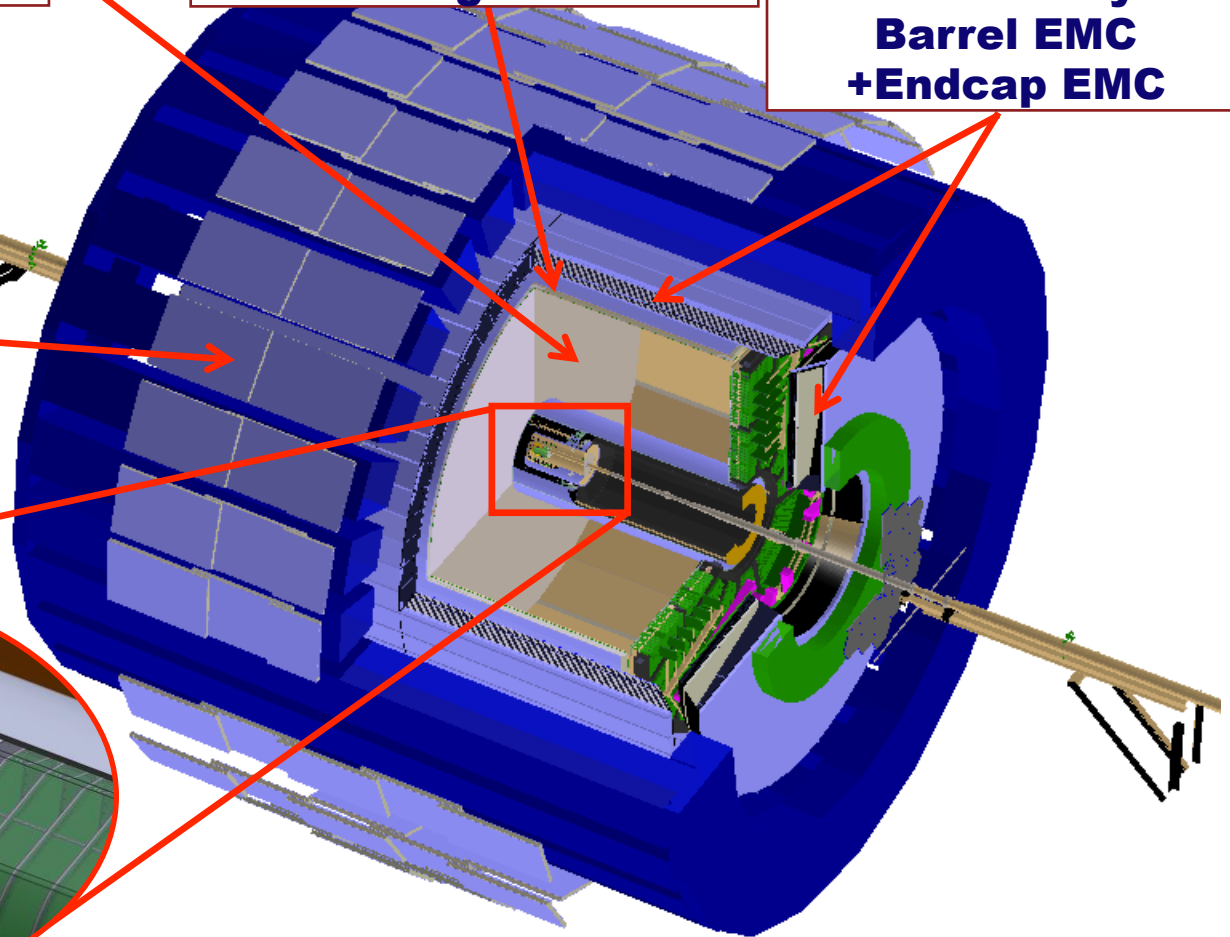
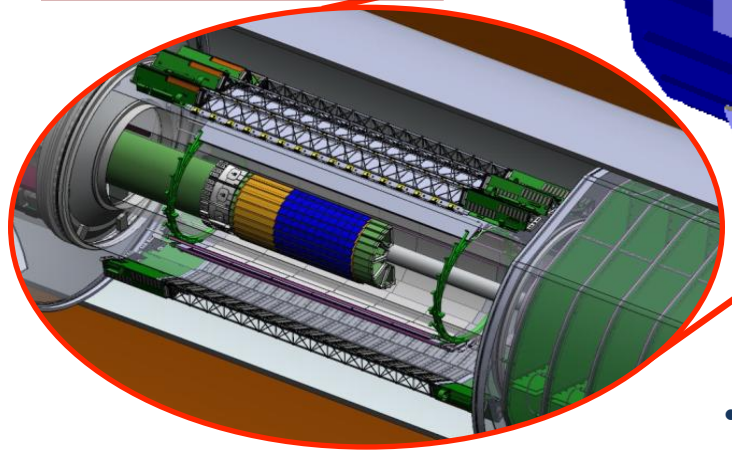

- Full azimuthal particle identification at middle rapidity



# HFT Design

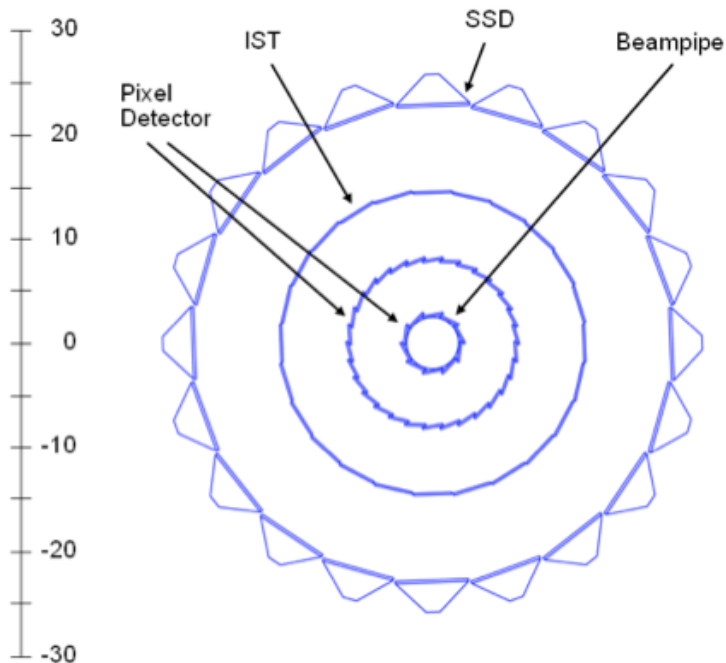

## Silicon Strip Detector:

existing detector with new faster electronics

double sided silicon strip modules with 95  $\mu\text{m}$  pitch

$\sigma_{r-\phi}$ : 20  $\mu\text{m}$

$\sigma_z$ : 740  $\mu\text{m}$

radius: 22 cm

$X/X_0$ : 1 %

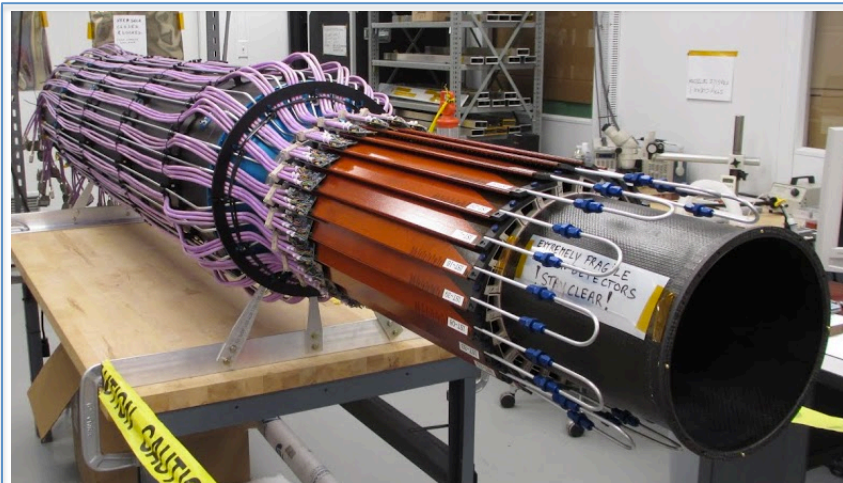

## Intermediate Silicon Tracker:

single-sided double-metal silicon pad

sensors with 600  $\mu\text{m}$   $\times$  6 mm pitch

$\sigma_{r-\phi}$ : 170  $\mu\text{m}$

$\sigma_z$ : 1800  $\mu\text{m}$

radius: 14 cm

$X/X_0 < 1.5$  %

See details at poster M-30 by Yaping Wang

The task of SSD and IST is to guide the track from TPC to the innermost PXL detector with high hit density.

# Pixel Detector Design

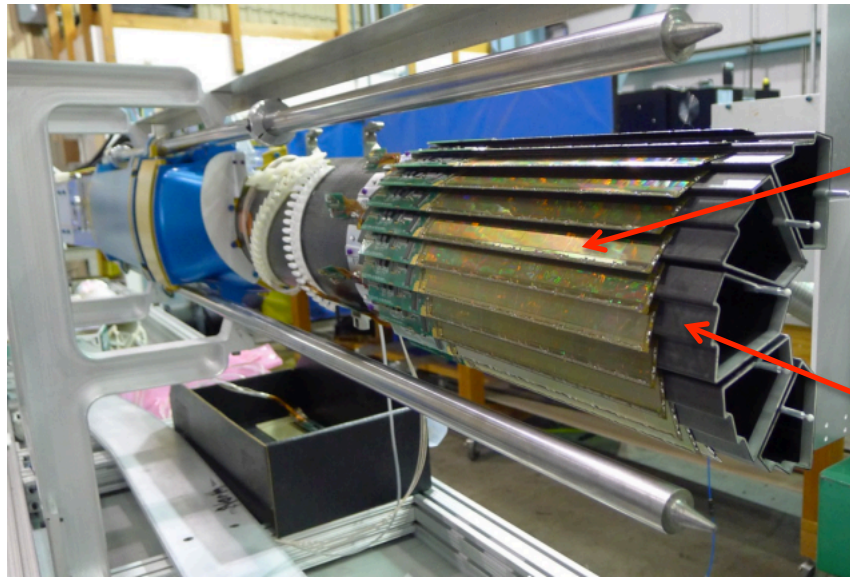

PIXEL detector

- 10 sectors \* 4 ladders (1 inner + 3 outer) \* 10 Monolithic Active Pixel Sensors
  - 20.7  $\mu\text{m}$  pixel pitch
  - thinned down to 50  $\mu\text{m}$
  - used in a collider experiment for the first time
- light carbon fiber support
- radius:
  - 2.9 cm (inner)
  - 8.2 cm (outer)
- $\sigma$ :  $\sqrt{\left(\frac{20.7}{\sqrt{12}}\right)^2 + 5^2}$  = 7.8  $\mu\text{m}$  vibration
- $X/X_0$ : 0.4 % / layer
- 360 M pixels in total
- air cooled

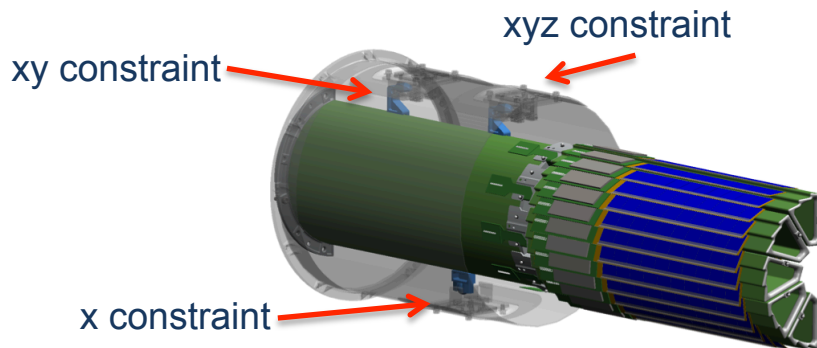

3 kinematic mounts locate the PXL half on the PXL supporting tube.

PXL insertion can be done in ~12 hours, by pushing PXL halves along rails and latching on kinematic mounts.

2 sets of PXL detectors and 40 spare ladders are made, to replace damaged detector units when needed.



# Monolithic Active Pixel Sensors

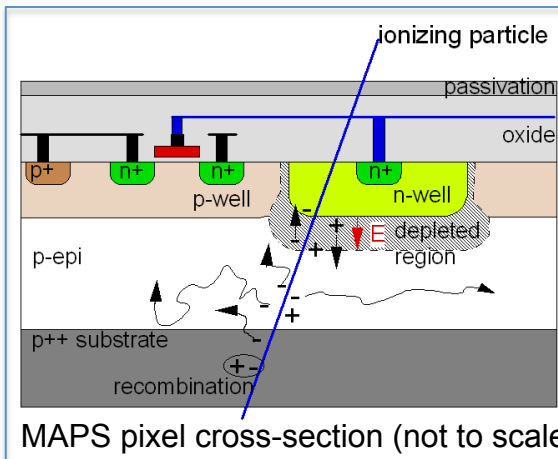

- signal mainly from thermal diffusion in the low-doped epitaxial layer (10~15  $\mu\text{m}$ )
- 100 % fill-factor
- MIP signal < 1000 electrons
- collected in large E-field depleted region

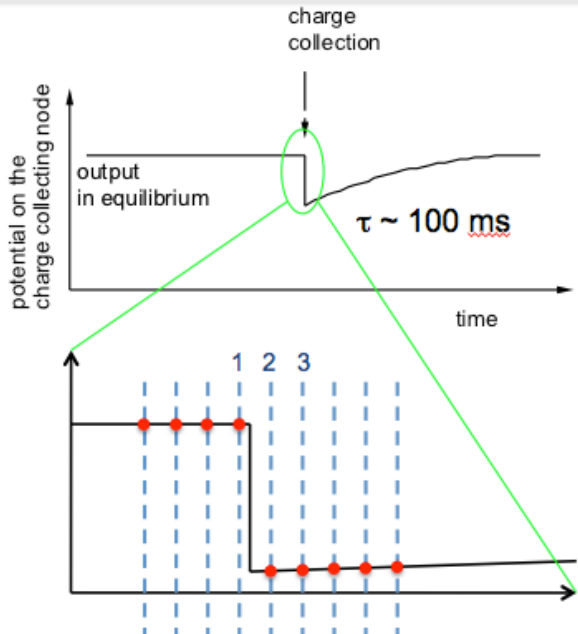

(Sample 1 – Sample 2) > threshold => hit  
 (Sample 2 – Sample 3) < threshold => no hit

Correlated Double Sampling

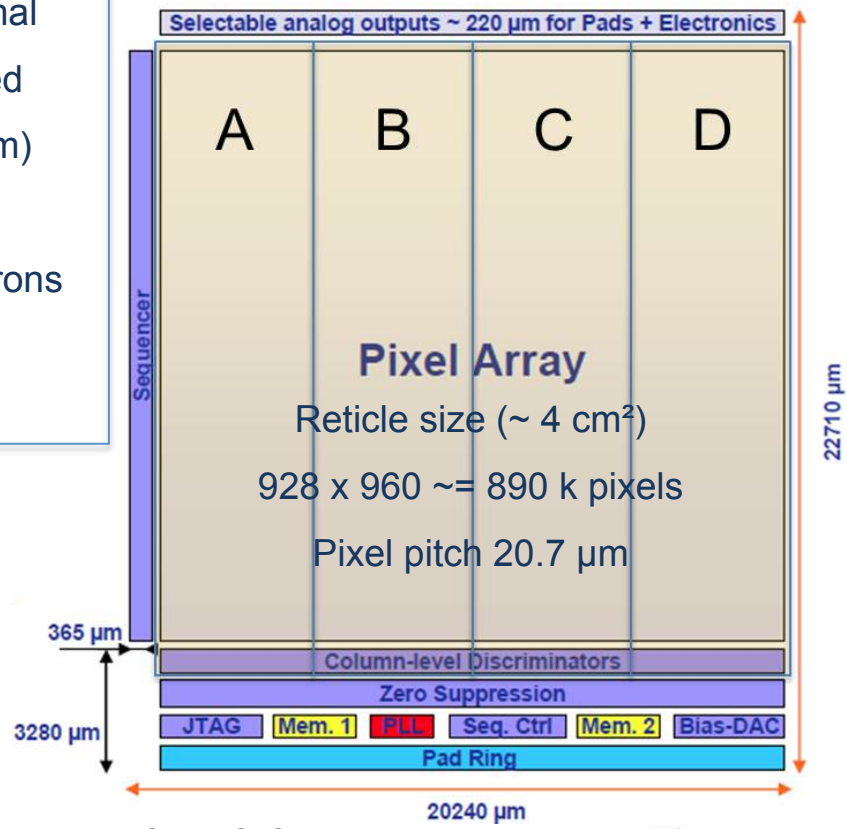
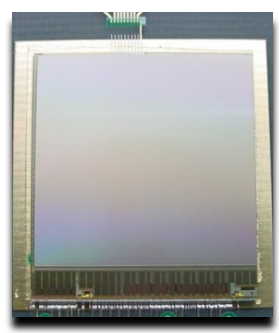

Developed by PICSEL group of IPHC-Strasbourg.  
 (Marc Winter et al.)

Thank you!

- standard commercial CMOS technology
- sensor and signal processing are integrated in the same silicon wafer
- discriminator & zero suppression in sensor, readout raw hits directly
- integration time 185.6  $\mu\text{s}$



# HFT Status

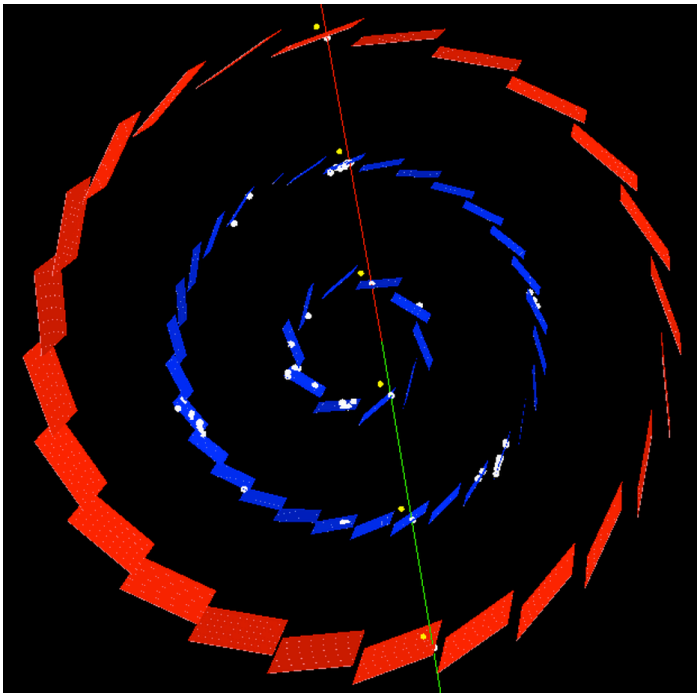

a cosmic event

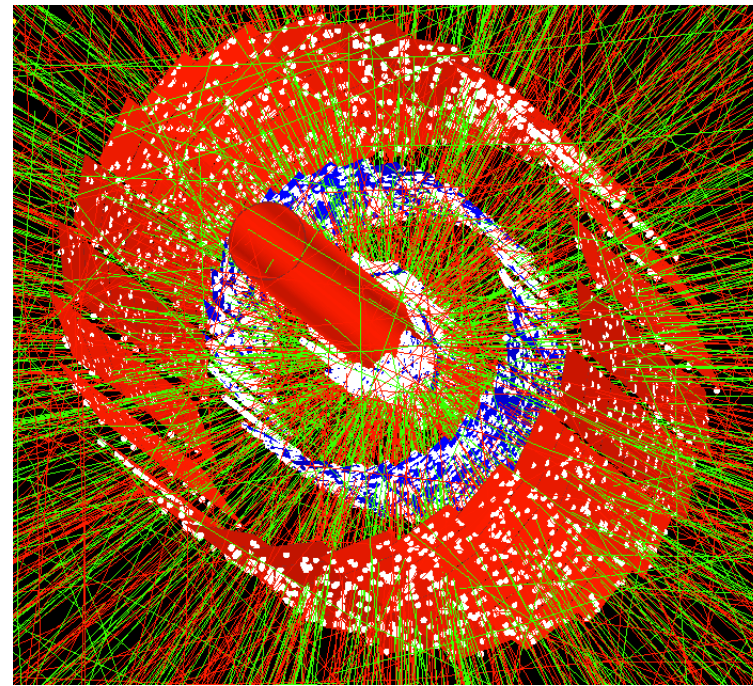

a Au+Au 200 GeV event

- The full system has been installed for RHIC 2014 running.
- Cosmic data were taken for commission, alignment and efficiency studies (before Feb. 9 and whenever there is long time with no beam)
- Some detector performance optimization during 14.5 GeV Au+Au run (Feb. 14 ~ Mar. 11)
- 200 GeV Au+Au data taking with PXL and IST since Mar. 15
- SSD is still in commission – SSD and IST are redundant in guiding TPC track to PXL.

# Signal, Pedestal and Noise Scan

IST hit ADC spectrum w/ track angle correction

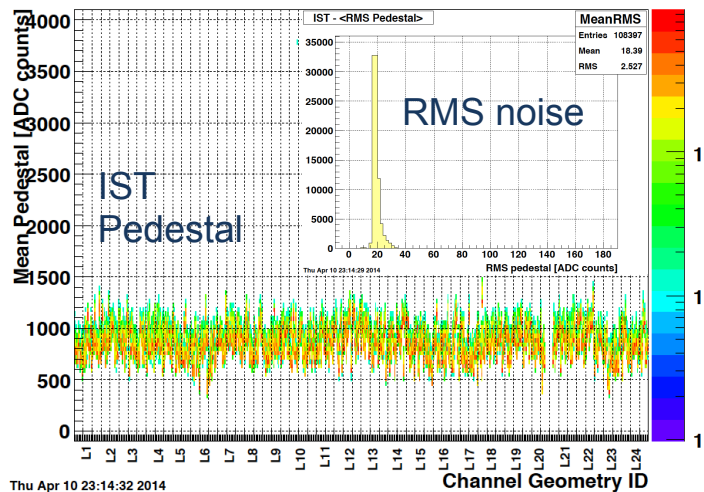
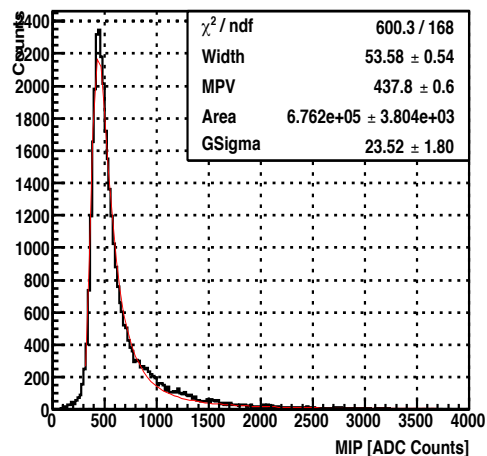

IST signal with MIP  
MVP ~ 440 ADCs

IST has stable pedestal and RMS level  
over all channels

- signal to noise ratio ~ 23

See details at poster M-30 by Yaping Wang

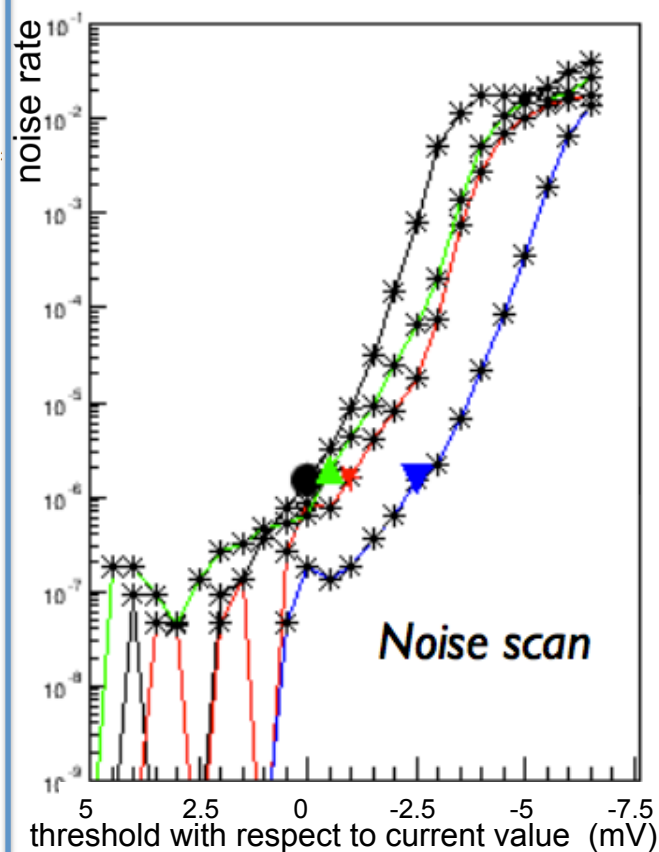

Optimize sub-array thresholds in a  
PXL sensor for noise rate =  $2.e-6$

- Noise data for PXL and pedestal data for IST and SSD are taken at least once per day without beam, to monitor PXL noise rate, hot pixels, and calibrate IST pedestal.

# Damage and Remediation

Global  $\phi$  vs. global Z, inner

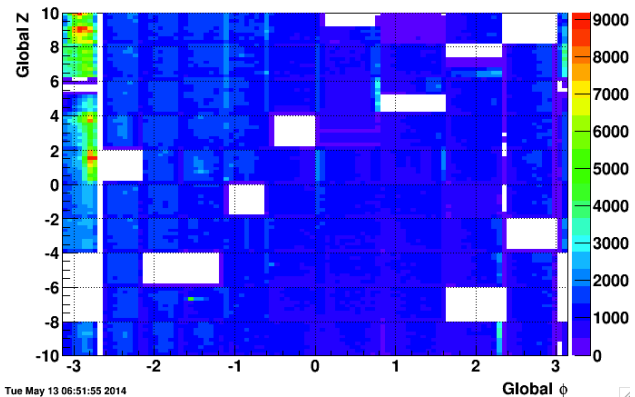

Tue May 13 06:51:55 2014

Z vs.  $\phi$  of hits in PXL inner layer

Global  $\phi$  vs. global Z, outer

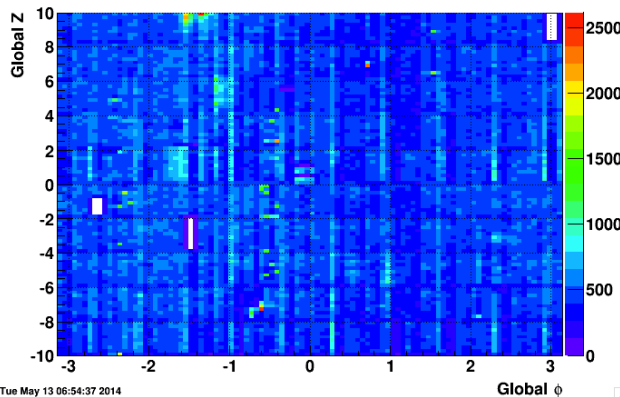

Tue May 13 06:54:37 2014

Z vs.  $\phi$  of hits in PXL outer layer

Entries 1267721

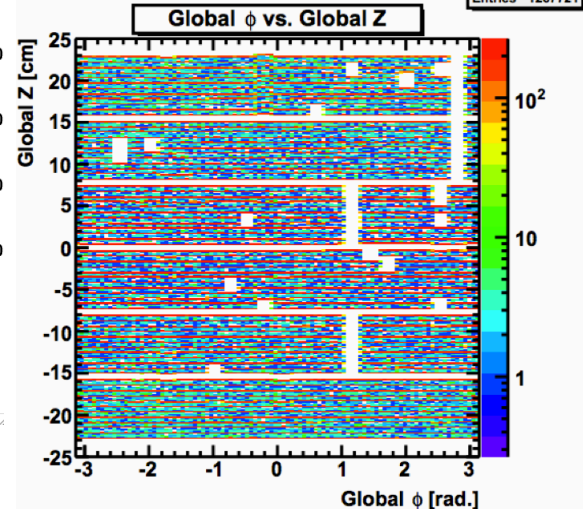

Z vs.  $\phi$  of IST hits

layer	inactive units
PXL inner	14 %
PXL outer	1 %
IST	4 %

Most PXL sensor damages appears to be radiation related damage possibly due to latch up in thinned sensors.

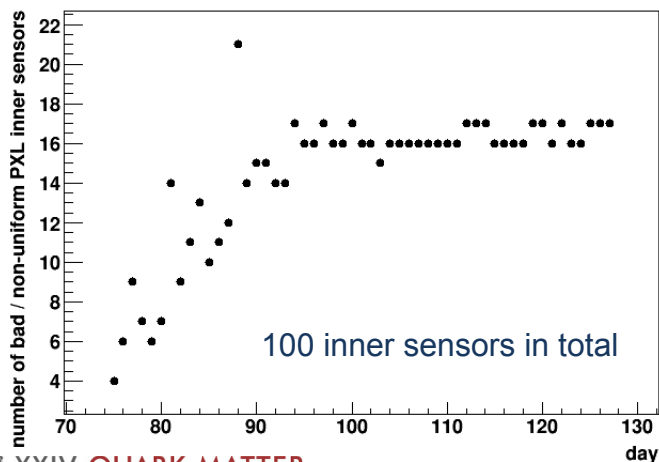

Minimal or no damage for > 1 month: our operational methods were successful at stopping or greatly reducing the rate of damage.

- PXL and IST are only turned on when collision rate < 55 kHz.
- the full PXL detector resets every 15 minutes
- Latch up thresholds changed from 400 mA to 120 mA above the measured operating current for each ladder



# Efficiency

Low statistics of near horizontal cosmic

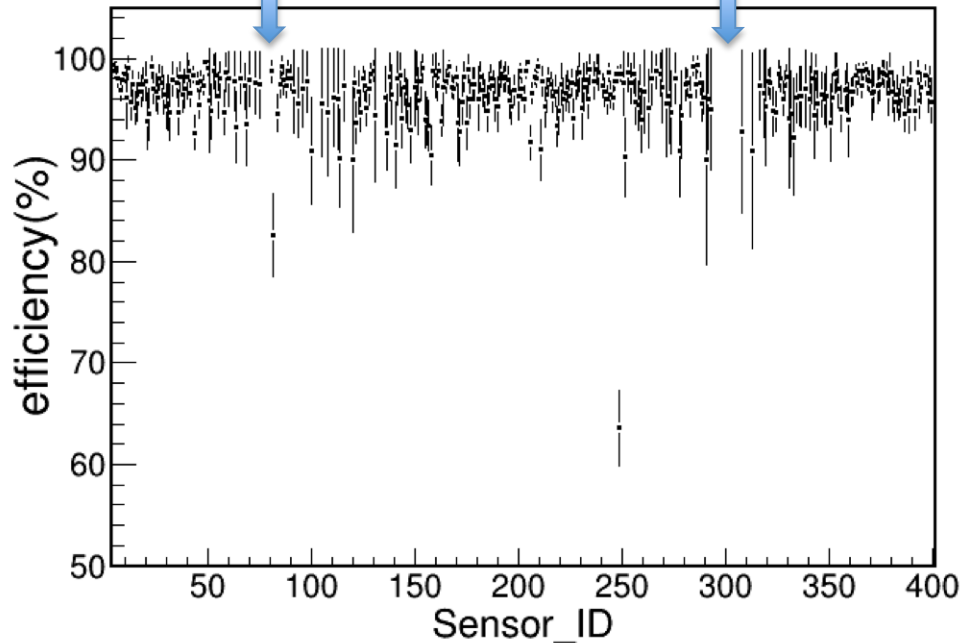

PXL sensor efficiency measured with cosmic ray:  
hits / projection

- Before the detector response optimization and running with the beam
- Average = 97.2 %
- Tuning for including HFT in tracking is going on...

operational threshold / noise = 5

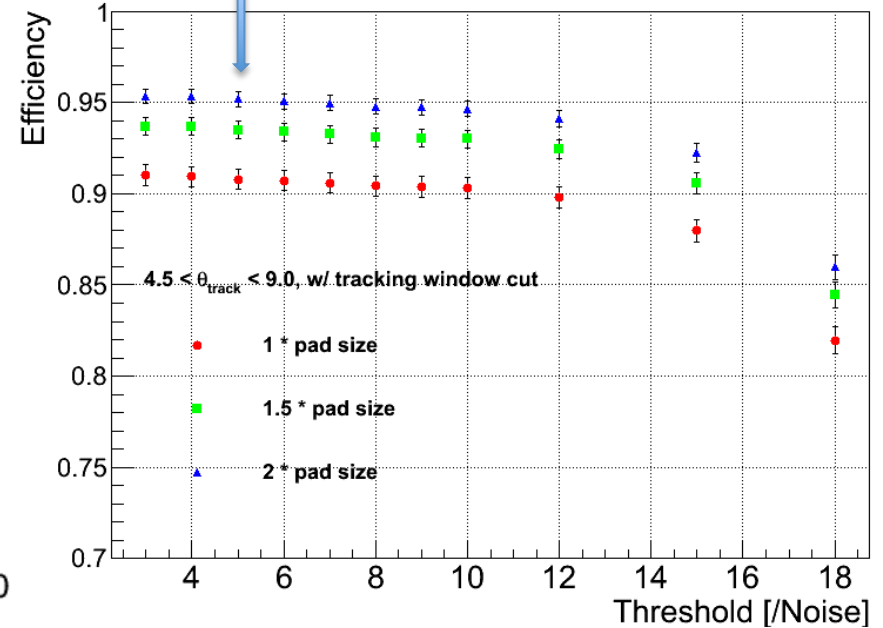

IST efficiency measured with cosmic ray:  
hits / projection

~ 95 % at operational threshold / noise



# Survey and Alignment

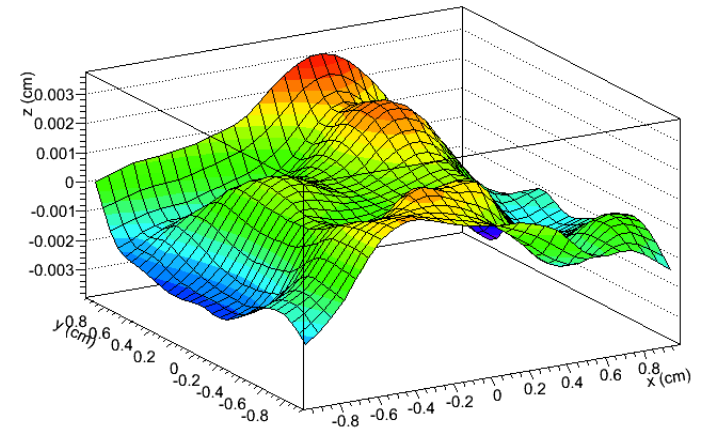
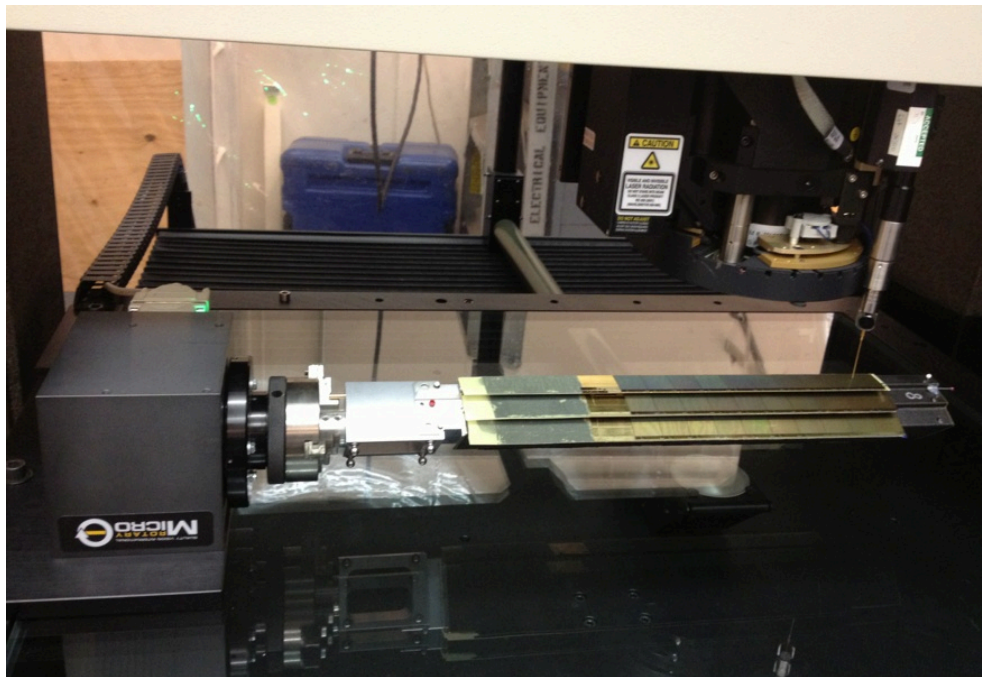

PXL sensor surface profile from survey  
 $\pm 30 \mu\text{m} >$  PXL hit error

Coordinate Measurement Machine is used to survey HFT detector parts.

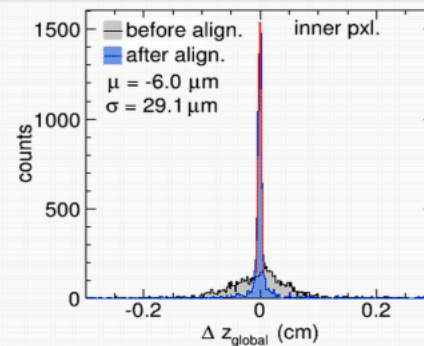
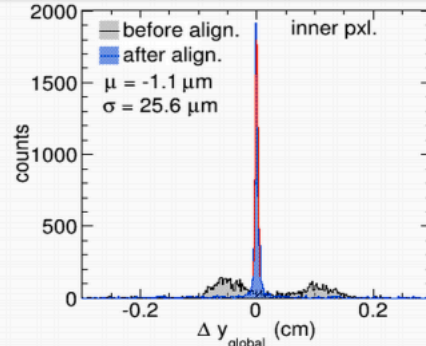
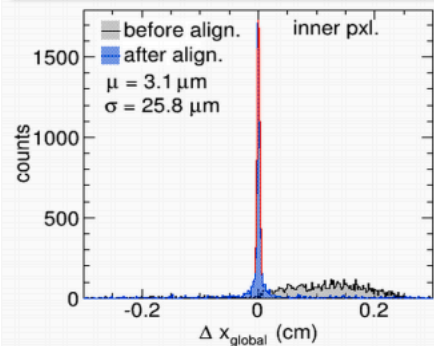

PXL hit residual distribution before and after PXL half to half alignment

Cosmic ray is used to align different HFT detector parts.

see details at poster M-13  
 by Michael Lomnitz

# Hit Residual and Track DCA

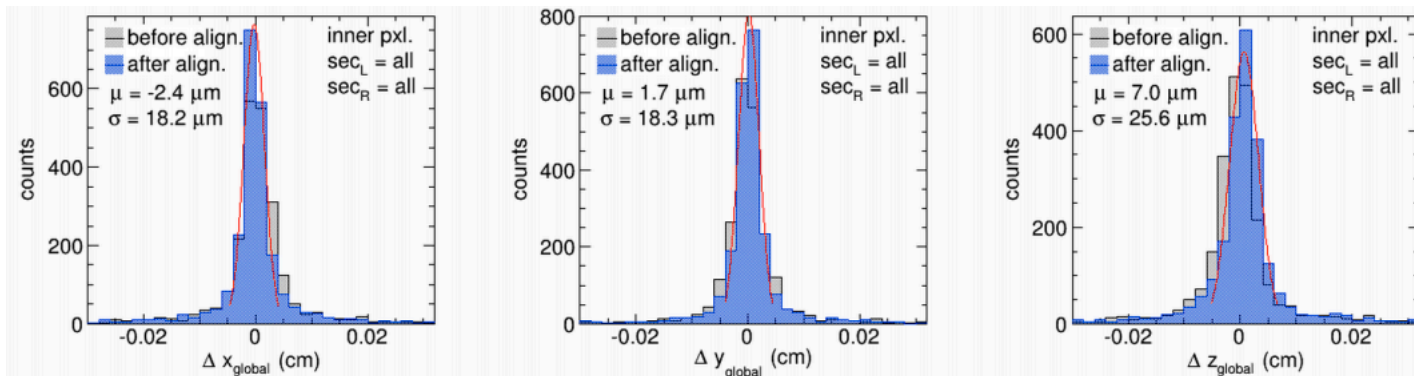

PXL hit residual to cosmic track projection after PXL sector alignment:  $\sigma < 25 \mu\text{m}$ , match the design goal

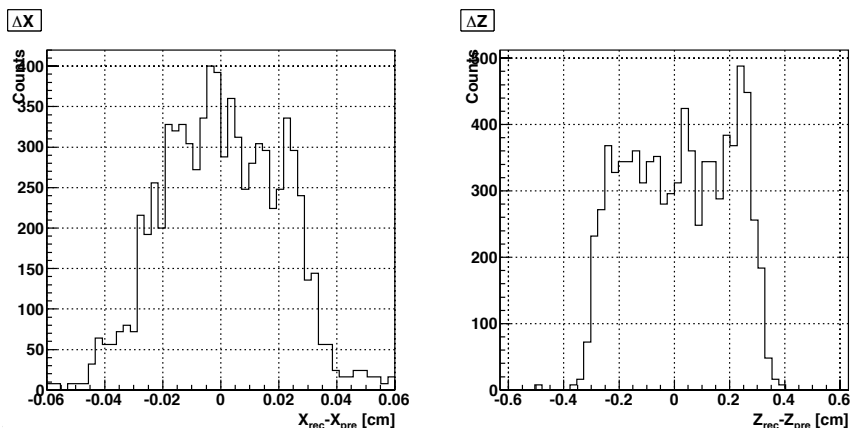

IST hit residuals to cosmic track projection:

$\sigma_x = 200 \mu\text{m}$ ,  $\sigma_z = 1800 \mu\text{m}$

match IST pad size

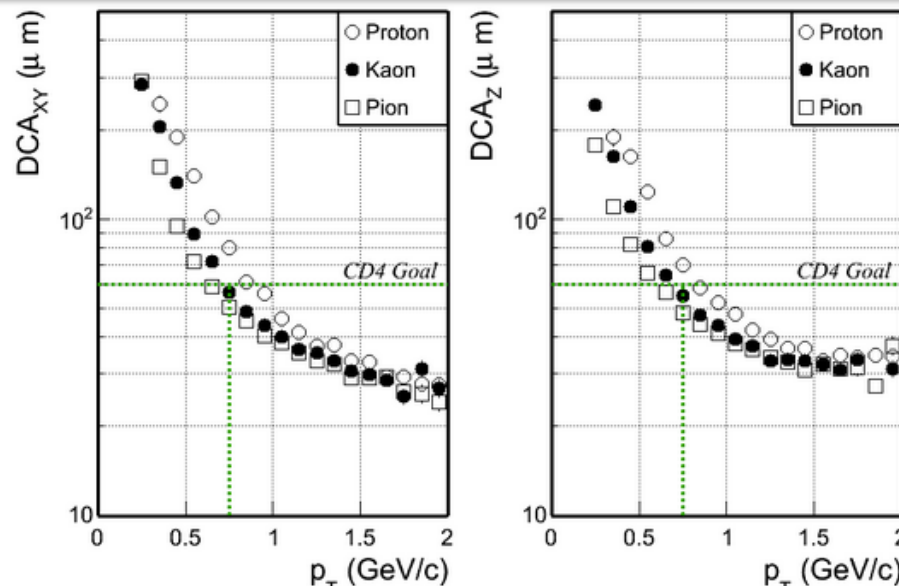

DCA resolution for tracks with TPC + 1 IST hit + 2 PXL hits

~ 30  $\mu\text{m}$  at high  $p_T$

Below project goal: 60  $\mu\text{m}$  for kaon with  $p_T = 750 \text{ MeV}/c$

# Summary

- STAR Heavy Flavor Tracker will enable or enhance many open heavy flavor measurements, by reconstructing open heavy flavor hadrons with displaced decay vertices.
- State-of-art MAPS technology is used for the first time in a collider experiment in the PXL detector.
- All 3 sub-detectors (PXL, IST, SSD) are finished with construction and inserted into STAR before RHIC year 2014 running.
- With survey and preliminary alignment, we already achieved  $\sim 30$  microns pointing resolution for high  $p_T$  tracks reconstructed with HFT hits.
- Data taking with PXL and IST is on a good trend to reach our goal: 1.3 B Au+Au 200 GeV minimum bias events. p+p 200 GeV and more Au+Au data will come in run 15 & 16.
- New physics results with HFT will greatly enhance our understanding of QGP created at RHIC.

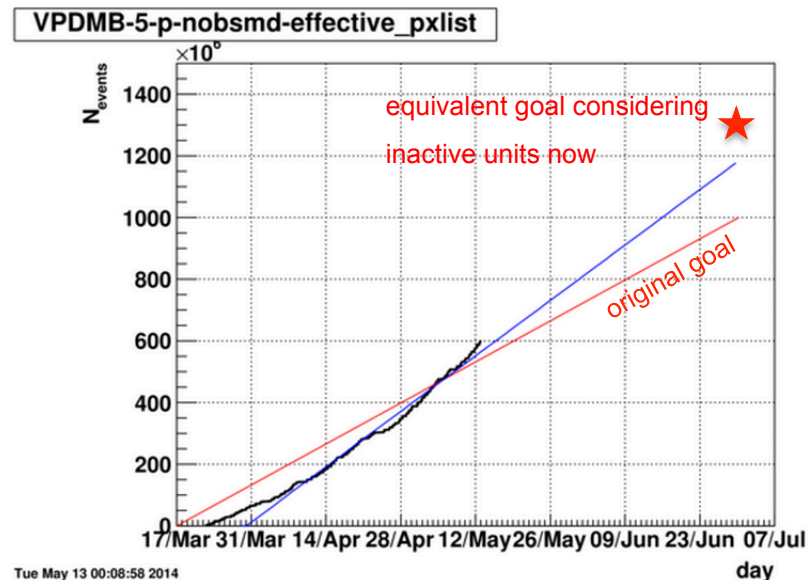

# Thank you

